

Collection

CATALOGUE 2025 - MANERA



25

STAY SALTY

SUMMARY

01 OUR BRAND ³

STAY SALTY /3 - CORE PRINCIPLES /4

02 NEWS 2025 ⁵

03 NEOPRENE ⁸

OVERVIEW /9 - HOW TO CHOOSE /11 - PRICE MAP /12 - ALT /13 - MAGMA /15
X10D /18 - SEAFARER /20 - GROMS /26 - THICKNESS REPARTITION /27

04 NEOPRENE ACCESSORIES ²⁸

OVERVIEW /28 - BASELAYERS /29 - HOOD & CAP /30 -
BOOTS /32 - GLOVES /33

05 HARNESSES ³⁵

OVERVIEW /35 - HOW TO CHOOSE /36 - HALO /37 - ECLIPSE /40 -
EXO /42 - LIFT WING /44 - HARNESS ACCESSORIES /46

06 BOARDBAGS ⁴⁷

OVERVIEW /47 - TRAVELBAGS /48 - DAYBAGS /49 -
FOILBAGS /50 - BACKPACKS /51

07 WATERWEAR & PROTECTIONS ⁵²

OVERVIEW /52 - WATERGEAR /53 - ESKIMO /56 - PROTECTIONS /57
VAGABOND /58 - SFOAM HELMET /59 - LEASHES /60

08 BOARDSHORTS ⁶¹

OVERVIEW /61 - BOARDSHORTS /62

09 APPAREL ⁶³

10 SIZECHARTS ⁶⁴

11 OUR VALUES ⁶⁶

SUSTAINABILITY /66 - STAY FAMILY /67

Salty is a feeling

It's getting wild on the ocean,
the sea spray all over our faces.

It's part of who you become
when you're out there, lost with friends.

It's the salt encrusted in us
after a long day playing with the waves.

After shower the salt is gone,
but the feeling stays there.

Stay salty.



Stay salty no matter what

It is our passion for water that is expressed through our brand.

We are passionate and we surround ourselves with passionate people.

Keep it in the family

Our brand has been 100% owned and run by the same family since its inception.

We are building our business to last for generations, not just our lifetime project.

Support local shops

We started from nothing and we support today those who supported us yesterday.

Let's keep the experience of entering a surf shop alive for future generations.



Core principles

Marketing to inspire

We use marketing to inspire, to gather and to encourage everyone to spend more time out there.

Our products are made to brave the worst conditions, we want to see them used wisely.

Quality is our speciality

We offer high-quality products. We are experts in innovation, creating high-performance and durable products.

We work hard so that no one has to get out of the water because it's too cold or they don't feel comfortable.

Stay green

At MANERA, we have decided not to base our marketing on the «Eco-friendly» aspect, because our strength lies in the performance of our products.

We have therefore chosen to explain, with full transparency, the actions we are implementing for the environment on our website.

Manera

NEWS 2025



x

New Seafarer

Our classic SEAFARER, only supercharged.

The SEAFARER brings us back to the essentials of what makes a good wetsuit, nothing more, nothing less: warmth, comfort, durability. It's a no-bullshit wetsuit with MANERA's renowned fit and construction.

With the 2025 SEAFARER, our goal was to offer a quality wetsuit with the best possible value for money. The result is a wetsuit featuring all the SEAFARER+ technologies and fabrics, retailing at 320€ for a 4.3mm. (-25% compared to the 2024 SEAFARER+, with the exact same technologies).

It becomes a no-brainer for a customer that wants high quality without "breaking the bank".

In order to make sure everyone can find the right SEAFARER, we have added new models and thicknesses: Women, Men, FZ, BZ, Hooded, Shorties... The SEAFARER range is as complete as possible.

NEWS 2025

x

New Foil leash - Lite

The FOIL LEASH - LITE is a lighter, more compact version of the FOIL LEASH.

Built using a very similar process to the F-ONE wing wrist leash, the FOIL LEASH goes unnoticed while riding. This technology allowed us to use a reduced diameter, and a shorter length leash, that won't drag in the water or get tangled inside your foil. The specific bungee softness has been designed to make sure the board doesn't slingshot back to you during a wipeout.

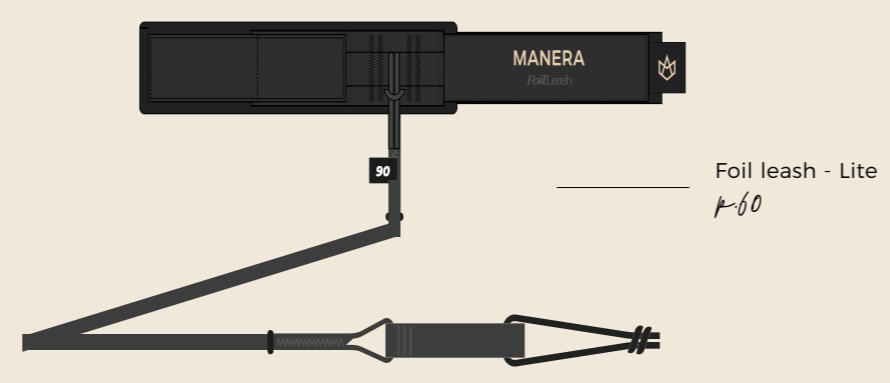

x

New Neoprene boots

We have updated all our neoprene boots patterns for 2025.

The cuff features two vertical panels instead of a horizontal one, increasing its flexibility for a better entry. Once inside the boots, the upper flexible panel increases comfort without compromising support, as the side panels have been kept intact.

The result is an easier entry, a better overall comfort, and an increased durability.



NEWS 2025

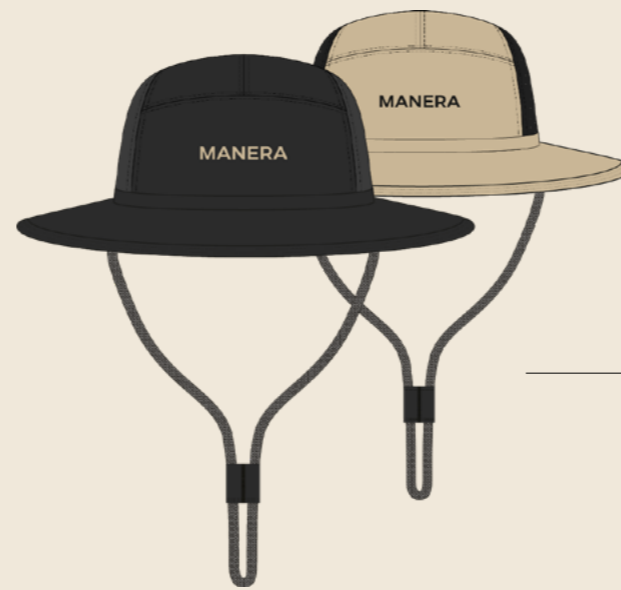

Bobby - 5 panels
P-55

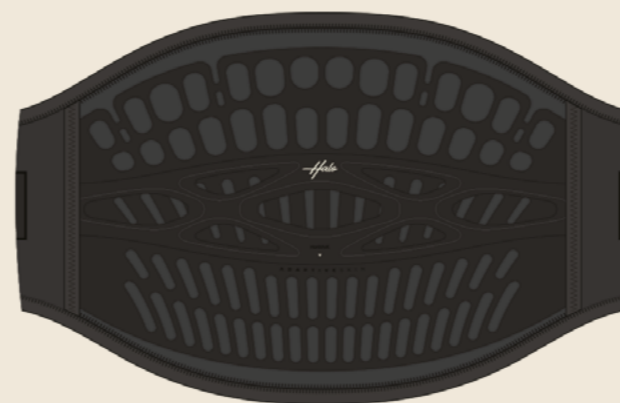

Halo V2
P-57

x

New Bobby - 5 Panels

The BOBBY is not an average hat. Built in the same fabric as our technical boardshorts, it is made to be light, to dry fast and to resist against UV rays and saltwater.

The "5-panels" version features mesh panels on both sides to improve airflow and prevent overheating during the warm summer days. The fit is also conceived for action: fitting closer to the head, the 5-panels version will hold better in the strong wind and waves than our standard BOBBY.

It is meant to spend the day out there: Before, during and after your sessions.

x

New Halo V2

Our HALO harness encountered great success for its innovative technology, but it lacked reliability. We have worked very hard to correct this and came up with a flawless V2.

The "Adaptive skin", "Pivot Inter" and "Pivot Exter" parts have been redesigned to provide a much higher resistance without compromising comfort. Thorough testing has been conducted at the factory and inside our office's lab, under the same protocol as for the Quick Release ISO norm.

Our goal for that V2 is to offer our breakthrough technology in a harness that you can trust.

NEWS 2025

x

New Deflater Bag

The DEFLATER BAG, unlike the more versatile OFFSHORE VEST, is dedicated solely to downwind deflators. Made of ripstop and Dacron from kites and wings, it's ultra-light, waterproof and resistant, so you don't feel it on your back. Compression straps and Velcro fasteners secure it to your back when empty and when riding upwind. Then, its large pocket and roll-top closure allow you to fit a wing of 5m² or more inside. An opening on the underside allows water to be drained off when the wing is stowed away, and the ultra-simple closing system ensures that no water enters once the wing is inside, even during heavy falls. It also features a compartment for a hydration pack (non included).

The DEFLATER BAG is the ultimate gear for your downwind deflators!



Deflater bag
P-54

x

New Socks

At MANERA, we aim at keeping you warm, all the way down to your feet !

Discover our take on socks: with a warm, thick MAGMA version and a thinner, more flexible X10D version. Carry the "Stay Salty" vibe one step at a time!



Socks
P-65



NEOPRENE

OVERVIEW

Men

Women

MAGMA

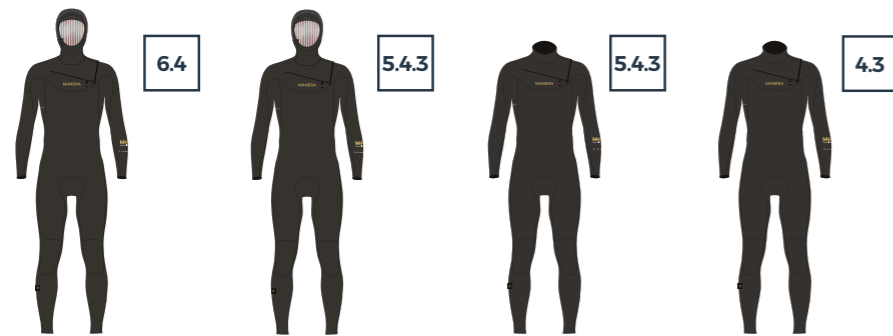

MAGMA HD - FZ
Ref. 22241-0100
Colors. BLACK

MAGMA HD - FZ
Ref. 22241-0101
Colors. BLACK

MAGMA - FZ
Ref. 22241-0102
Colors. BLACK

MAGMA - FZ
Ref. 22241-0103
Colors. BLACK

X10D

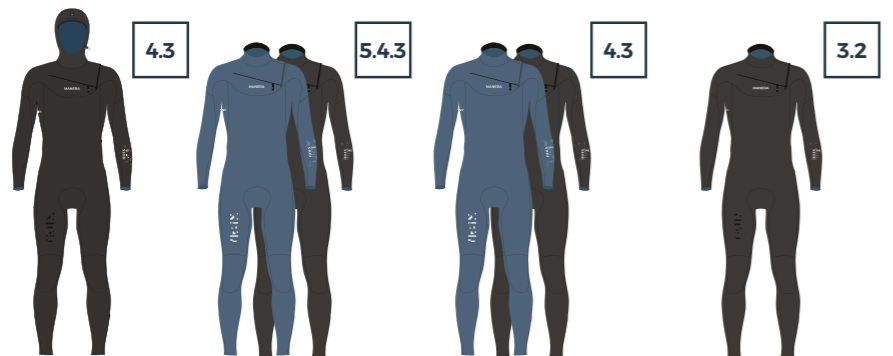

X10D HD - FZ
Ref. 22221-0201
Colors. BLACK

X10D - FZ
Ref. 22221-0202
Colors. PEWTER / BLACK

X10D - FZ
Ref. 22221-0203
Colors. PEWTER / BLACK

X10D - FZ
Ref. 22221-0204
Colors. BLACK

ALT



ALT - FZ
Ref. 22231-1902
Colors. BLACK

ALT - FZ
Ref. 22231-1903
Colors. BLACK

SEAFARER

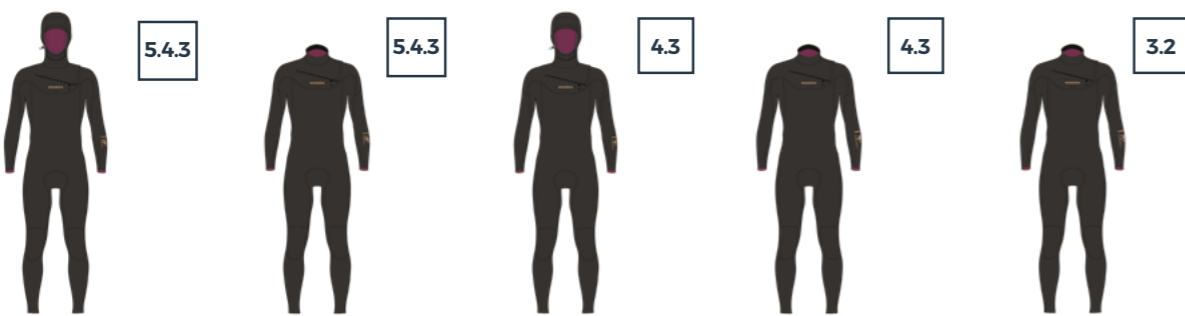

SEAFARER - FZ
Ref. 22251-0300
Colors. BLACK

SEAFARER - FZ
Ref. 22251-0302
Colors. BLACK

SEAFARER - FZ
Ref. 22251-0301
Colors. BLACK

SEAFARER - FZ
Ref. 22251-0303
Colors. BLACK

SEAFARER - FZ
Ref. 22251-0304
Colors. BLACK



SEAFARER - BZ
Ref. 22251-0502
Colors. BLACK

SEAFARER - BZ
Ref. 22251-0503
Colors. BLACK

SEAFARER - BZ
Ref. 22251-0504
Colors. BLACK

SEAFARER - FZ
Ref. 22251-0306
Colors. BLACK

SEAFARER - FZ
Ref. 22251-0305
Colors. BLACK

SEAFARER - FZ
Ref. 22251-0307
Colors. BLACK

MAGMA



MAGMA HD - FZ
Ref. 22241-1000
Colors. BLACK

MAGMA HD - FZ
Ref. 22231-1001
Colors. BLACK

MAGMA - FZ
Ref. 22241-1002
Colors. BLACK

MAGMA - FZ
Ref. 22231-1003
Colors. BLACK

GROMS



SEAFARER GROMS - FZ
Ref. 22251-2101
Colors. BLACK



SEAFARER GROMS - FZ
Ref. 22251-2102
Colors. BLACK



SEAFARER GROMS - FZ
Ref. 22251-2103
Colors. BLACK

SEAFARER

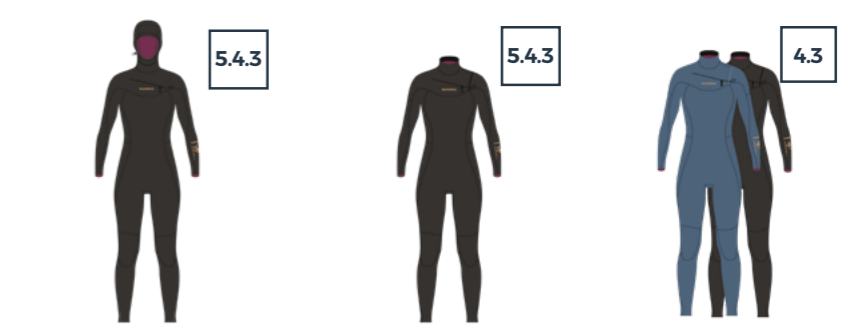

SEAFARER - FZ
Ref. 22251-3001
Colors. BLACK

SEAFARER - FZ
Ref. 22251-3002
Colors. BLACK

SEAFARER - FZ
Ref. 22251-3003
Colors. PEWTER / BLACK



SEAFARER - FZ
Ref. 22251-3004
Colors. PEWTER / BLACK

SEAFARER - BZ
Ref. 22251-5002
Colors. BLACK

SEAFARER - BZ
Ref. 22251-5003
Colors. BLACK



SEAFARER - BZ
Ref. 22251-5004
Colors. BLACK

SEAFARER - FZ
Ref. 22251-3005
Colors. PEWTER / BLACK

SEAFARER - FZ
Ref. 22251-3006
Colors. BLACK

NEOPRENE

OLD SEAFARER

Men



SEAFARER - FZ
Ref. 22221-0302
Colors. PEWTER / ANTHRACITE

SEAFARER - FZ
Ref. 22221-0303
Colors. PEWTER / ANTHRACITE

SEAFARER - FZ
Ref. 22221-0304
Colors. ANTHRACITE

SEAFARER - FZ
Ref. 22221-0306
Colors. ANTHRACITE



SEAFARER - BZ
Ref. 22221-0502
Colors. ANTHRACITE

SEAFARER - BZ
Ref. 22221-0503
Colors. ANTHRACITE

SEAFARER - BZ
Ref. 22221-0504
Colors. ANTHRACITE

SEAFARER - FZ
Ref. 22221-0305
Colors. ANTHRACITE

Women

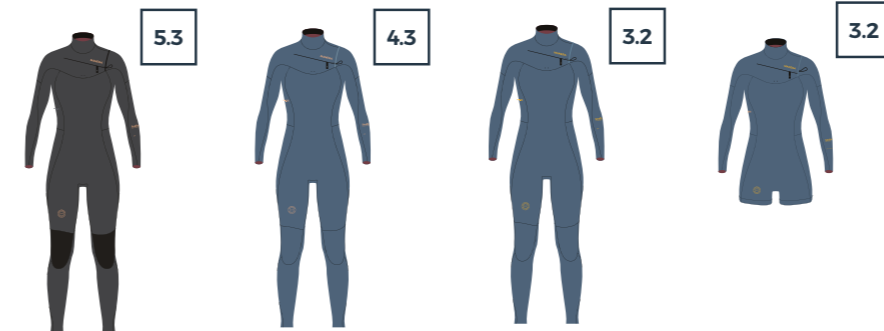

SEAFARER - FZ
Ref. 22221-3002
Colors. ANTHRACITE

SEAFARER - FZ
Ref. 22221-3003
Colors. PEWTER

SEAFARER - FZ
Ref. 22221-3004
Colors. PEWTER

SEAFARER - FZ
Ref. 22221-5002
Colors. PEWTER



SEAFARER - BZ
Ref. 22221-5002
Colors. ANTHRACITE

SEAFARER - BZ
Ref. 22221-5003
Colors. PEWTER

SEAFARER - BZ
Ref. 22221-5004
Colors. PEWTER

BIKISUIT - FZ
Ref. 22231-3006
Colors. BLACK

GROMS



SEAFARER GROMS - FZ
Ref. 22231-2101
Colors. BLACK



SEAFARER GROMS - FZ
Ref. 22231-2102
Colors. BLACK



SEAFARER GROMS - FZ
Ref. 22231-2103
Colors. BLACK

SEAFARER

SEAFARER

SEAFARER +

SEAFARER +

HOW TO CHOOSE

WETSUITS

MAGMA

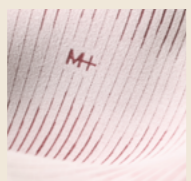

MAGMA / 50% PLUS



RECYCLED / 50% X10D

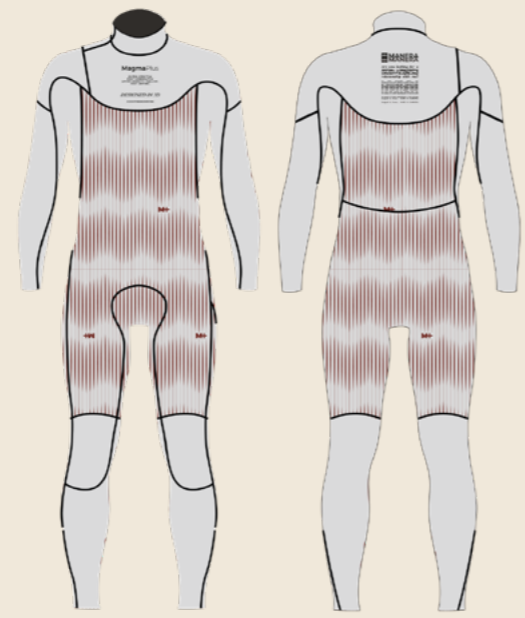

FLEXIBILITY	WARMTH	COMFORT
95%	90%	100%

ALT



RECYCLED / 50% MAGMA

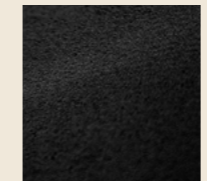

RECYCLED / 50% X10D



FLEXIBILITY	WARMTH	COMFORT
95%	85%	100%

X10D



X10D / 50% FLEECE



X10D / 50% JERSEY



FLEXIBILITY	WARMTH	COMFORT
100%	80%	100%



X10D / 10% FLEECE

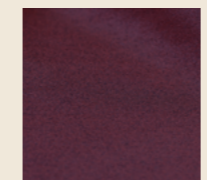

X10D / 90% JERSEY



FLEXIBILITY	WARMTH	COMFORT
95%	75%	95%

PRICE MAP

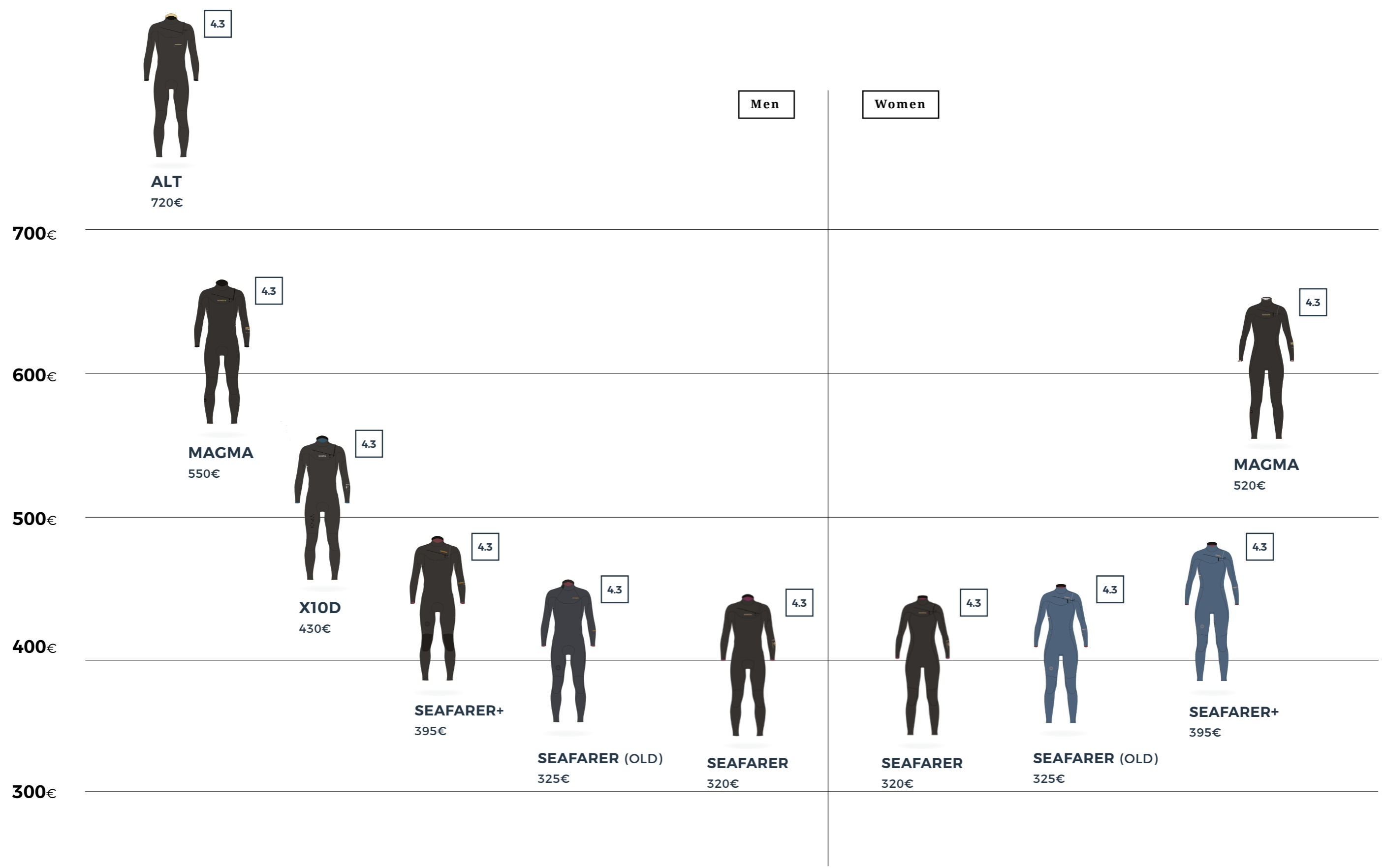

ALT

KEY FEATURES

Materials

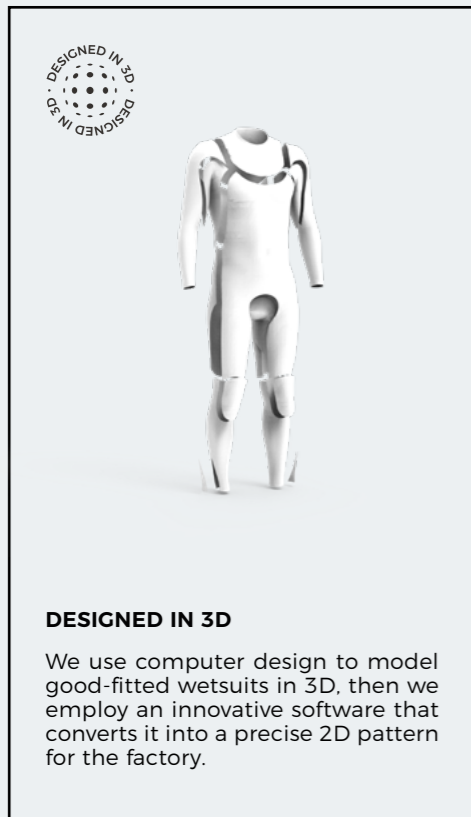

DESIGNED IN 3D

We use computer design to model good-fitted wetsuits in 3D, then we employ an innovative software that converts it into a precise 2D pattern for the factory.

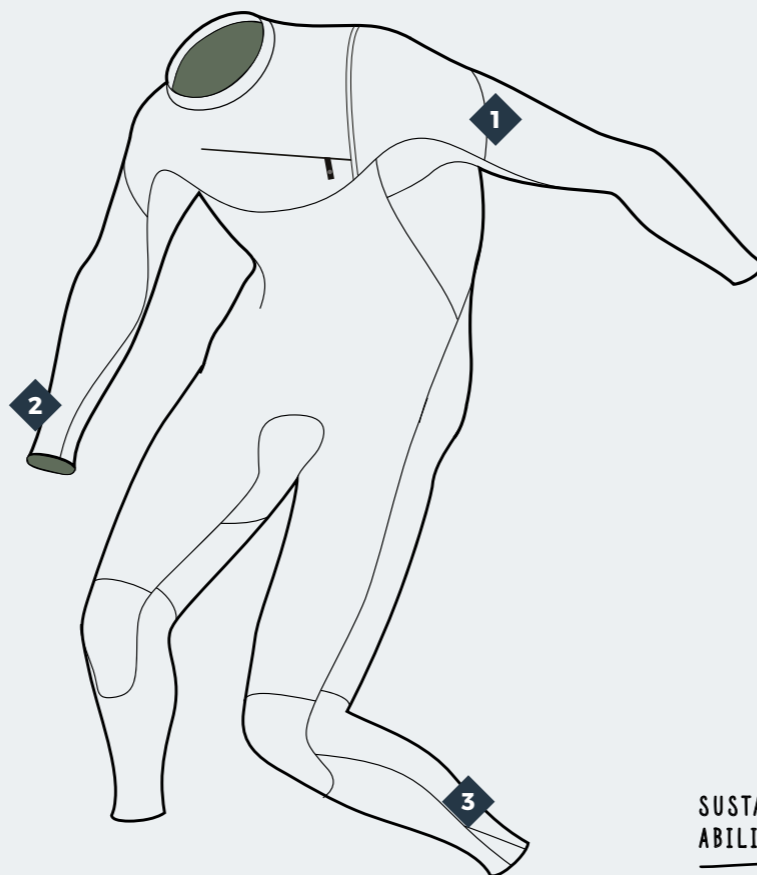

RECYCLED MAGMA

- RECYCLED MAGMA**
- 45% Recycled polyester
 - 47% nano bamboo charcoal polyester,
 - 8% Spandex

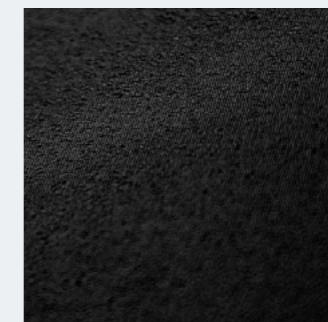

RECYCLED JERSEY

- RECYCLED JERSEY**
- Assembled with recycled nylon jerseys
 - Stretch & light
 - Provides smooth & silky feeling on the skin

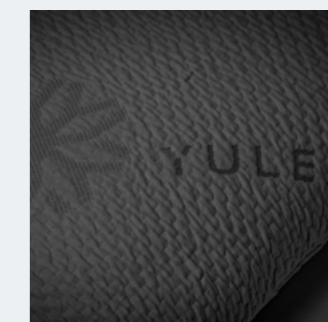

YULEX

- YULEX NATURAL FOAM**
- Taped from Hevea trees
 - Certified FSC forests

SUSTAINABILITY



WASTE MATERIALS ARE RECYCLED

+



FACTORY POWERED WITH SOLAR ENERGY

+



DOPE DYEING CONSUMES 60% LESS WATER

+



RECYCLED/COMPOSTABLE PACKAGING

Technologies



- 1 SD² TAPE II**
- Triple glued / Blind stitched / Inside tape welded by an air heater machine
 - New material brings more durability & Flex
 - 100% waterproof



- 2 SEALING PRINT**
- Keep the water away
 - Keep legs & arms panels in place

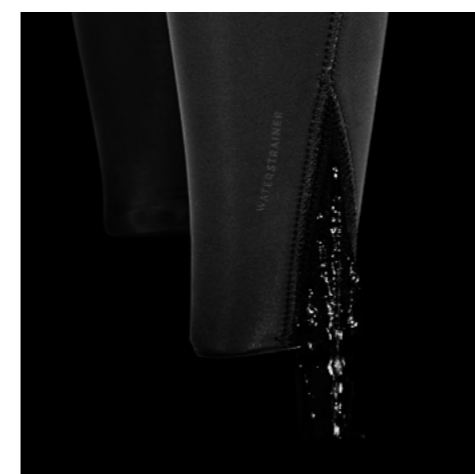

- 3 WATER STRAINER**
- Drains the water out of the leg
 - Continue the session in the best possible conditions

CHARACTERISTICS

ALT stands for « Alternative ». We have built a greener alternative to conventional wetsuits, with performance in mind. It features a 100% natural YULEX rubber and recycled jerseys besides our standard sustainable processes.

WE BELIEVE THE ALT REPRESENTS A NEW GENERATION OF HIGH-PERFORMANCE WETSUITS THAT HAS A MORE REASONABLE IMPACT ON THE PLANET.



Alt. 25



Men



ALT FRONTZIP

5.4.3

DETAILS

REF. **22231-1902**
SIZING. XS-S-St-Ms-M-Mt-Ls-L-XL-XXL
COLORS. BLACK

FLEXIBILITY **95%**
WARMTH **85%**
COMFORT **100%**



ALT FRONTZIP

4.3

DETAILS

REF. **22231-1903**
SIZING. XS-S-St-Ms-M-Mt-Ls-L-XL-XXL
COLORS. BLACK

FLEXIBILITY **100%**
WARMTH **80%**
COMFORT **100%**

Warmth & comfort

MAGMA

KEY FEATURES

Materials

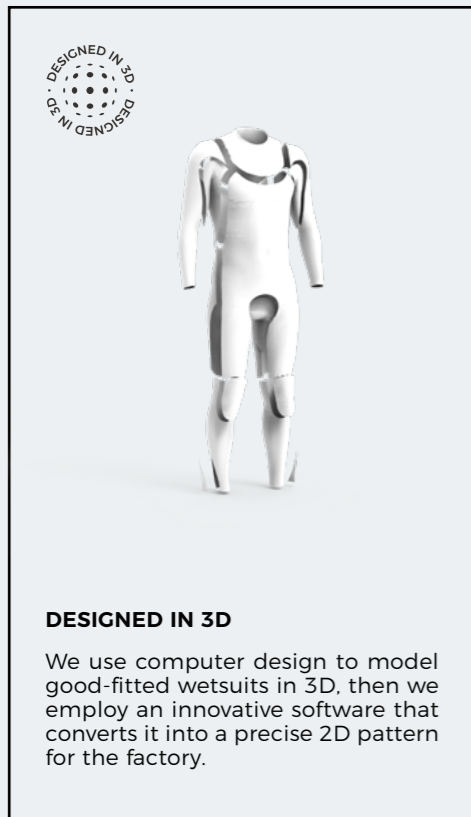

DESIGNED IN 3D

We use computer design to model good-fitted wetsuits in 3D, then we employ an innovative software that converts it into a precise 2D pattern for the factory.

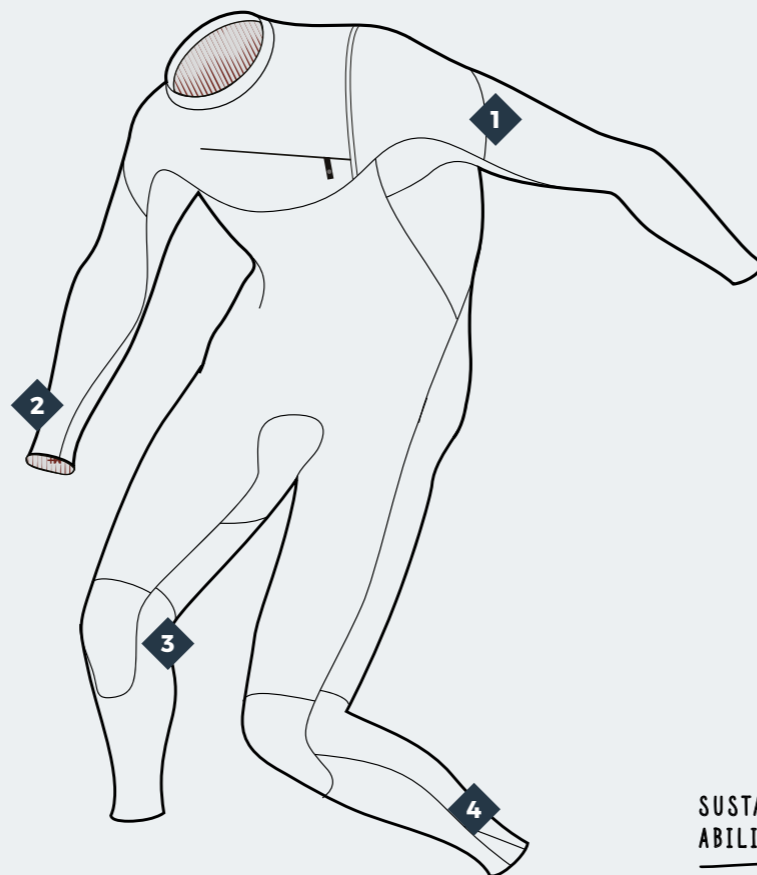

M+

- MAGMA PLUS**
- New generation of thermal materials that insulates & keep you warm
 - Best drying time on the market
 - Lighter than a classic fleece



RECYCLED JERSEY

- RECYCLED JERSEY**
- Assembled with recycled nylon jerseys
 - Stretch & light
 - Provides smooth & silky feeling on the skin



AIRFOAM NEOPRENE

- AIRFOAM**
- Made to be light, improving comfort & endurance
 - Best flex & insulation on the market
 - Quilted touch

SUSTAINABILITY

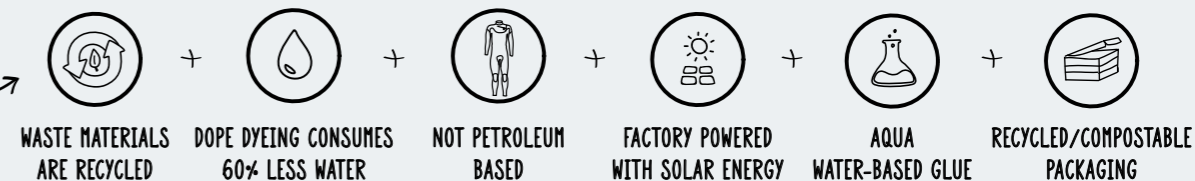

Technologies



- 1 SD² TAPE II**
- Triple glued / Blind stitched / Inside tape welded by an air heater machine
 - New material brings more durability & Flex
 - 100% waterproof



- 2 SEALING PRINT**
- Keep the water away
 - Keep legs & arms panels in place



- 3 BACK KNEE EMBOSS**
- Helps the neoprene to bend more naturally
 - Greater comfort during flexion



- 4 WATER STRAINER**
- Drains the water out of the leg
 - Continue the session in the best possible conditions

CHARACTERISTICS

The Meteor Magma is made for cold and windy winter days. Its Magma+ fleece acts both as an insulator and heat generator. It also dries 30% faster than a classic fleece.

IT IS YOUR WEAPON OF CHOICE AGAINST WINTER.

Magma. 25



Men



MAGMA 6.4
HOODED - FRONT ZIP

DETAILS
REF. 22241-0100
SIZING. XS-S-St-Ms-M-Mt-Ls-L-XL-XXL
COLORS. BLACK

FLEXIBILITY 80%
WARMTH 110%
COMFORT 100%



MAGMA 5.4.3
HOODED - FRONT ZIP

DETAILS
REF. 22241-0101
SIZING. XS-S-St-Ms-M-Mt-Ls-L-XL-XXL
COLORS. BLACK

FLEXIBILITY 85%
WARMTH 100%
COMFORT 100%



MAGMA 5.4.3
FRONT ZIP

DETAILS
REF. 22241-0102
SIZING. XS-S-St-Ms-M-Mt-Ls-L-XL-XXL
COLORS. BLACK

FLEXIBILITY 90%
WARMTH 90%
COMFORT 100%



MAGMA 4.3
FRONT ZIP

DETAILS
REF. 22241-0103
SIZING. XS-S-St-Ms-M-Mt-Ls-L-XL-XXL
COLORS. BLACK

FLEXIBILITY 95%
WARMTH 90%
COMFORT 100%

Magma. 25



Women



MAGMA 6.4
HOODED - FRONTZIP

DETAILS
REF. 22241-1000
SIZING. XS-S-M-ML-L-XL-XXL
COLORS. BLACK

FLEXIBILITY 80%
WARMTH 110%
COMFORT 100%



MAGMA 5.4.3
HOODED - FRONTZIP

DETAILS
REF. 22231-1001
SIZING. XS-S-M-ML-L-XL-XXL
COLORS. BLACK

FLEXIBILITY 85%
WARMTH 100%
COMFORT 100%

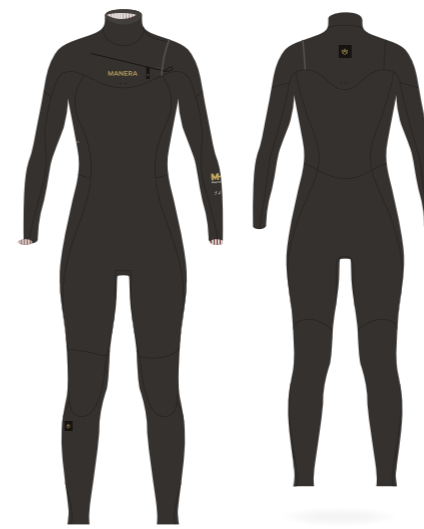

MAGMA 5.4.3
FRONTZIP

DETAILS
REF. 22241-1002
SIZING. XS-S-M-L-XL
COLORS. BLACK

FLEXIBILITY 90%
WARMTH 95%
COMFORT 100%



MAGMA 4.3
FRONTZIP

DETAILS
REF. 22231-1003
SIZING. XS-S-M-L-XL
COLORS. BLACK

FLEXIBILITY 95%
WARMTH 90%
COMFORT 100%

Stretch & light

X10D

KEY FEATURES

Materials

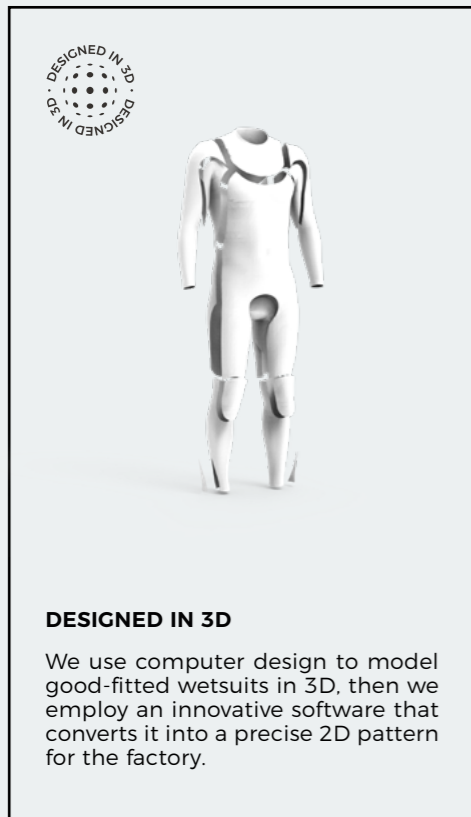

DESIGNED IN 3D

We use computer design to model good-fitted wetsuits in 3D, then we employ an innovative software that converts it into a precise 2D pattern for the factory.

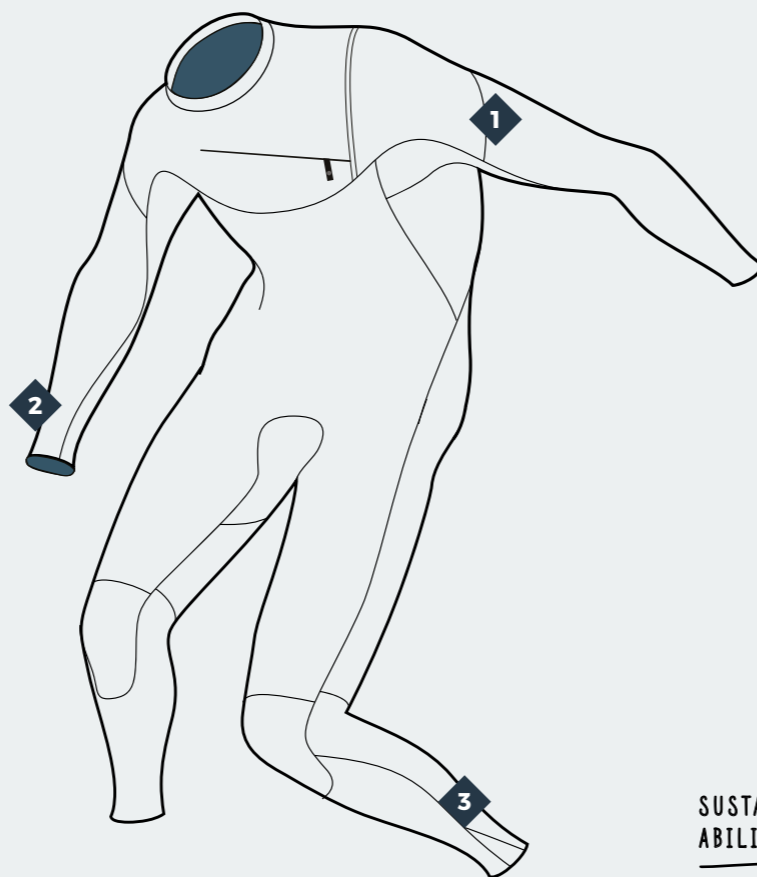

X10D FLEECE

- X10D FLEECE**
- Plush loops work as insulators & heat generators
 - Smooth, soft & comfy feeling against the skin
 - Dries fast

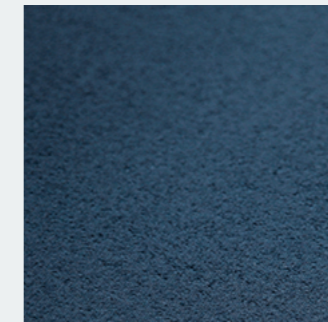

RECYCLED JERSEY

- X10D JERSEY**
- Light & stretch
 - Good feeling on the skin



AIRFOAM NEOPRENE

- AIRFOAM**
- Made to be light, improving comfort & endurance
 - Best flex & insulation on the market
 - Quilted touch

SUSTAINABILITY

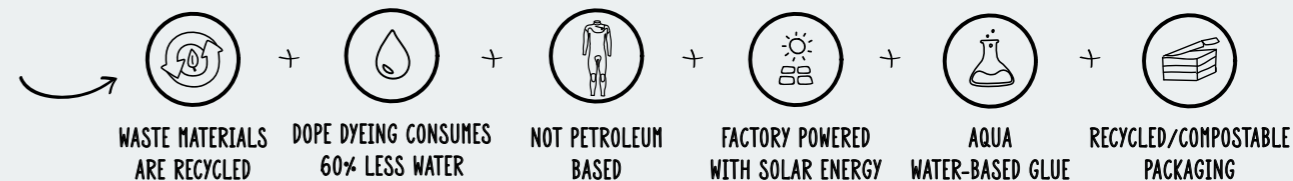

Technologies



- 1 SD² TAPE II**
- Triple glued / Blind stitched / Inside tape welded by an air heater machine
 - New material brings more durability & Flex
 - 100% waterproof



- 2 SEALING PRINT**
- Keep the water away
 - Keep legs & arms panels in place

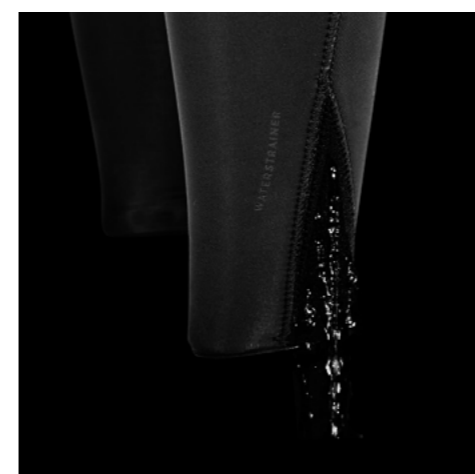

- 3 WATER STRAINER**
- Drains the water out of the leg
 - Continue the session in the best possible conditions

CHARACTERISTICS

The Meteor X10D is the ultimate performance wetsuit. In addition to excellent thermal protection, the X10D fleece interior gives flexibility and lightness while providing great comfort.

IF YOU ARE LOOKING FOR LIGHTNESS AND FREEDOM OF MOVEMENT, THIS IS THE WETSUIT YOU NEED.

X10D. 25



Men



X10D 4.3
HOODED - FRONT ZIP

DETAILS

REF.	22221-0201
SIZING.	XS-S-St-Ms-M-Mt-Ls-L-XL-XXL
COLORS.	BLACK

FLEXIBILITY	100%
WARMTH	90%
COMFORT	100%

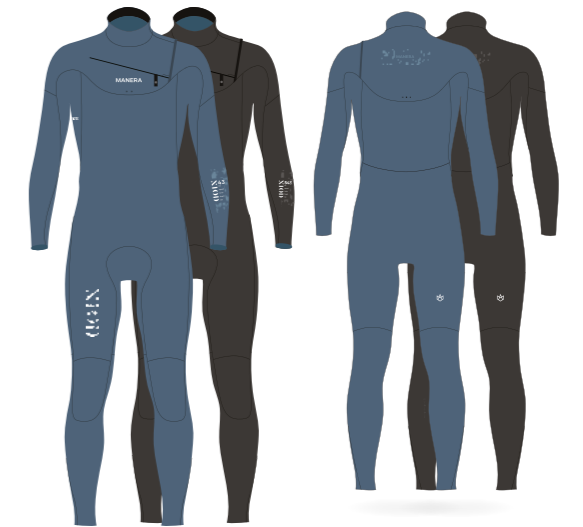

X10D 5.4.3
FRONTZIP

DETAILS

REF.	22221-0202
SIZING.	XS-S-St-Ms-M-Mt-Ls-L-XL-XXL
COLORS.	PEWTER / BLACK

FLEXIBILITY	95%
WARMTH	85%
COMFORT	100%

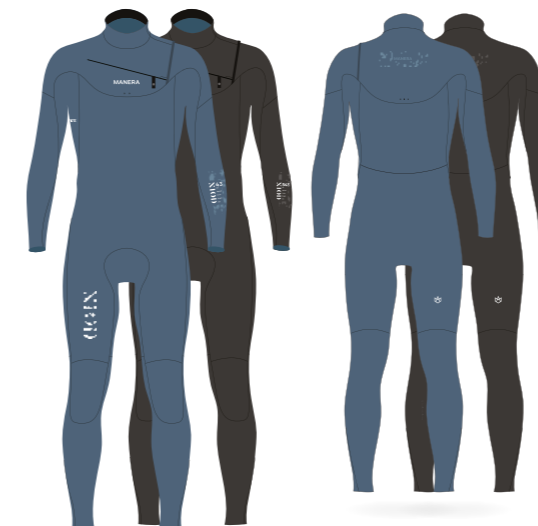

X10D 4.3
FRONTZIP

DETAILS

REF.	22221-0203
SIZING.	XS-S-St-Ms-M-Mt-Ls-L-XL-XXL
COLORS.	PEWTER / BLACK

FLEXIBILITY	100%
WARMTH	80%
COMFORT	100%



X10D 3.2
FRONTZIP

DETAILS

REF.	22221-0204
SIZING.	XS-S-St-Ms-M-Mt-Ls-L-XL-XXL
COLORS.	PEWTER / BLACK

FLEXIBILITY	100%
WARMTH	75%
COMFORT	100%

Back to basics

SEAFARER

KEY FEATURES

NEW

Materials

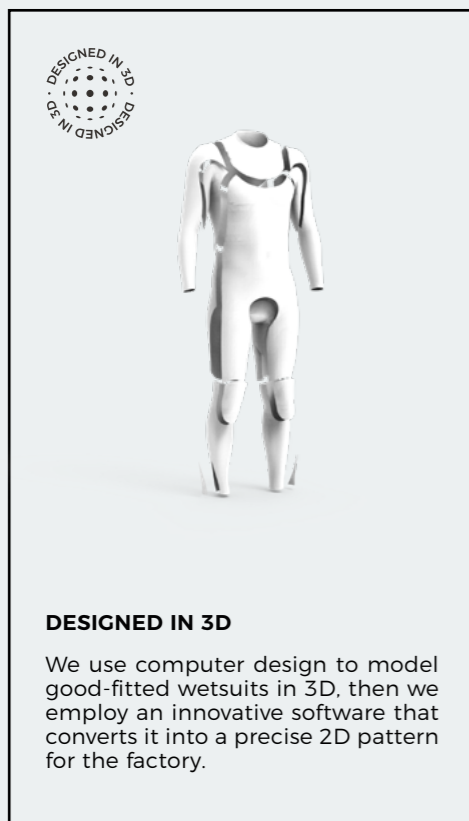

DESIGNED IN 3D

We use computer design to model good-fitted wetsuits in 3D, then we employ an innovative software that converts it into a precise 2D pattern for the factory.

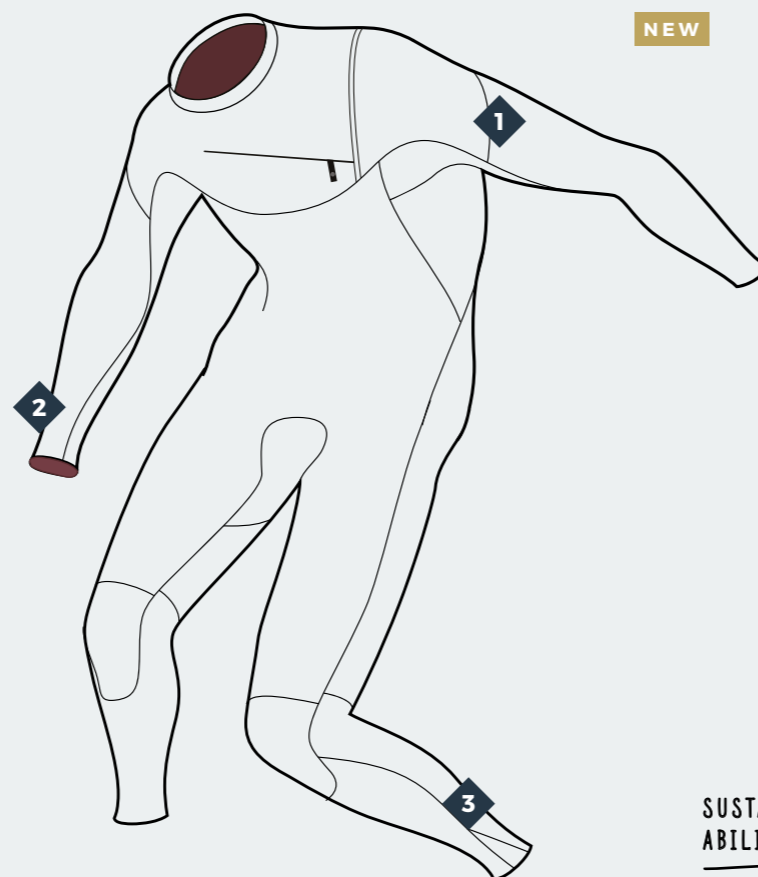

XTEND
FLEECE

- X10D FLEECE**
- Plush loops work as insulators & heat generators
 - Smooth, soft & comfy feeling against the skin
 - Dries fast

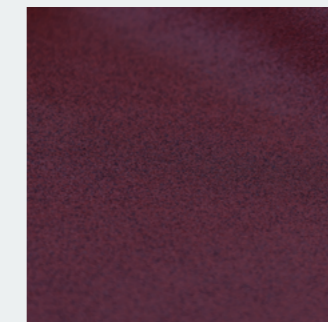

XTEND
JERSEY

- X10D JERSEY**
- Light & stretch
 - Good feeling on the skin



S-FOAM
NEOPRENE

- S-FOAM**
- Made from Limestone
 - Best flexibility, heat & durability ratio on the market

SUSTAINABILITY

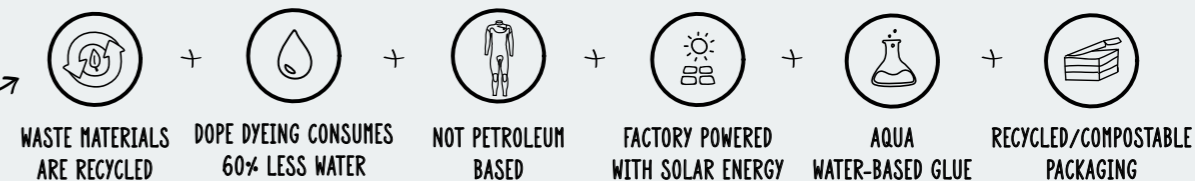

Technologies



- 1 SD² TAPE II**
- Triple glued / Blind stitched / Inside tape welded by an air heater machine
 - New material brings more durability & Flex
 - 100% waterproof



- 2 GBS SEAMS**
- Neoprene glued together & blind-stitched
 - High level of flexibility
 - 100% waterproof



- 3 SEALING PRINT**
- Keep the water away
 - Keep legs & arms panels in place

CHARACTERISTICS

The SEAFARER brings us back to the essentials of what makes a good wetsuit, nothing more, nothing less: warmth, comfort, durability. It's a no-bullshit wetsuit, with a good fit and finished with high-quality materials.

IF YOU ARE LOOKING FOR A HIGH-PERFORMANCE WETSUIT AT AN AFFORDABLE PRICE, THIS IS THE PERFECT MODEL.

Seafarer. 25



Men

NEW



SEAFARER
HOODED - FRONTZIP

5.4.3

DETAILS

REF. 22251-0300
SIZING. XS-S-St-Ms-M-Mt-Ls-L-XL-XXL
COLORS. BLACK

FLEXIBILITY 90%
WARMTH 95%
COMFORT 95%



SEAFARER
HOODED - FRONTZIP

4.3

DETAILS

REF. 22251-0301
SIZING. XS-S-St-Ms-M-Mt-Ls-L-XL-XXL
COLORS. BLACK

FLEXIBILITY 95%
WARMTH 90%
COMFORT 95%

NEW



SEAFARER
FRONTZIP

5.4.3

DETAILS

REF. 22251-0302
SIZING. XS-S-St-Ms-M-Mt-Ls-L-XL-XXL
COLORS. BLACK

FLEXIBILITY 90%
WARMTH 85%
COMFORT 95%



SEAFARER
FRONTZIP

4.3

DETAILS

REF. 22251-0303
SIZING. XS-S-St-Ms-M-Mt-Ls-L-XL-XXL
COLORS. BLACK

FLEXIBILITY 95%
WARMTH 80%
COMFORT 95%

NEW



SEAFARER
FRONTZIP

3.2

DETAILS

REF. 22251-0304
SIZING. XS-S-St-Ms-M-Mt-Ls-L-XL-XXL
COLORS. BLACK

FLEXIBILITY 100%
WARMTH 75%
COMFORT 95%



SEAFARER
BACKZIP

5.4.3

DETAILS

REF. 22251-0502
SIZING. XS-S-M-ML-L-XL-XXL
COLORS. BLACK

FLEXIBILITY 90%
WARMTH 85%
COMFORT 95%

NEW



SEAFARER
BACKZIP

4.3

DETAILS

REF. 22251-0503
SIZING. XS-S-M-ML-L-XL-XXL
COLORS. BLACK

FLEXIBILITY 95%
WARMTH 80%
COMFORT 95%



SEAFARER
BACKZIP

3.2

DETAILS

REF. 22251-0504
SIZING. XS-S-M-ML-L-XL-XXL
COLORS. BLACK

FLEXIBILITY 100%
WARMTH 75%
COMFORT 95%

KEY FEATURES

BACK ZIP

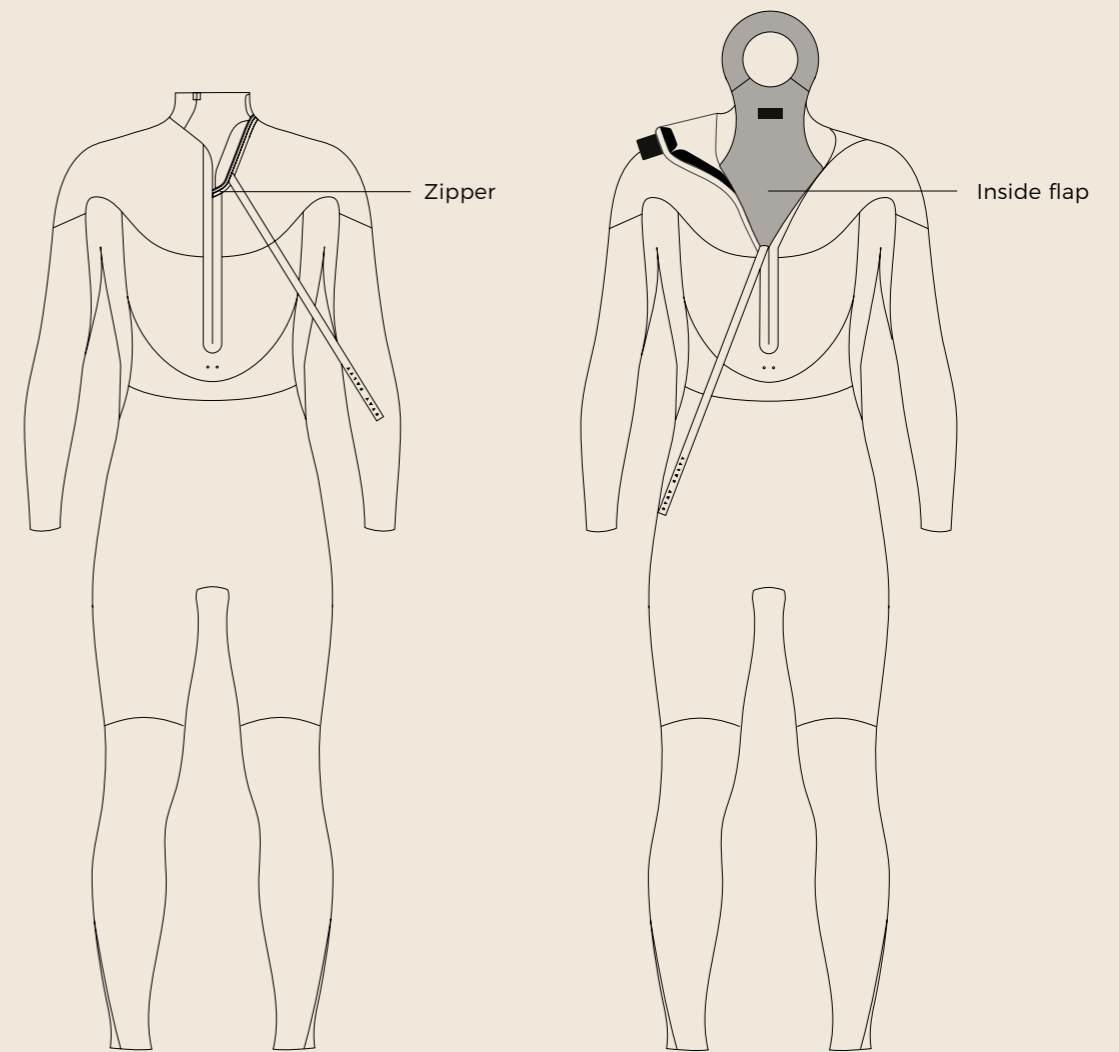

OUTSIDE

INSIDE

CHARACTERITCS

- We use a PK 8mm zip built in high quality nylon, it is a short zip (30cm) in order to maximize the back flexibility.
- An inside flap covers the back and goes around the neck, it protects the back from the outside zipper and allows a perfect waterproofness. It also adds a few millimeters of thickness to an area that is very exposed to wind.

NEW



SEAFARER
HYBRID

2.2

DETAILS

REF. **22251-0306**
SIZING. XS-S-St-Ms-M-Mt-Ls-L-XL-XXL
COLORS. BLACK

FLEXIBILITY **100%**
WARMTH **65%**
COMFORT **95%**

NEW



SEAFARER
SHORTY HYBRID

3.2

DETAILS

REF. **22251-0305**
SIZING. XS-S-St-Ms-M-Mt-Ls-L-XL-XXL
COLORS. BLACK

FLEXIBILITY **100%**
WARMTH **70%**
COMFORT **95%**

NEW



SEAFARER
SHORTY

2.2

DETAILS

REF. **22251-0307**
SIZING. XS-S-St-Ms-M-Mt-Ls-L-XL-XXL
COLORS. BLACK

FLEXIBILITY **100%**
WARMTH **60%**
COMFORT **95%**



Seafarer. 25



Women

NEW



SEAFARER
HOODED - FRONTZIP

5.4.3

DETAILS

REF. 22251-3001
SIZING. XS-S-M-L-XL-XXL
COLORS. BLACK

FLEXIBILITY 90%
WARMTH 95%
COMFORT 95%



SEAFARER
FRONTZIP

5.4.3

DETAILS

REF. 22251-3002
SIZING. XS-S-M-L-XL-XXL
COLORS. BLACK

FLEXIBILITY 90%
WARMTH 85%
COMFORT 95%

NEW



SEAFARER
FRONTZIP

4.3

DETAILS

REF. 22251-3003
SIZING. XS-S-M-L-XL-XXL
COLORS. BLACK - PEWTER

FLEXIBILITY 95%
WARMTH 80%
COMFORT 95%



SEAFARER
FRONTZIP

3.2

DETAILS

REF. 22251-3004
SIZING. XS-S-M-L-XL-XXL
COLORS. BLACK - PEWTER

FLEXIBILITY 100%
WARMTH 75%
COMFORT 95%

NEW



SEAFARER
BACKZIP

5.4.3

DETAILS

REF. 22251-5002
SIZING. XS-S-M-L-XL-XXL
COLORS. BLACK

FLEXIBILITY **90%**
WARMTH **85%**
COMFORT **95%**



SEAFARER
BACKZIP

4.3

DETAILS

REF. 22251-5003
SIZING. XS-S-M-L-XL-XXL
COLORS. BLACK

FLEXIBILITY **95%**
WARMTH **80%**
COMFORT **95%**



SEAFARER
BIKISUIT

2.0

DETAILS

REF. 22251-5006
SIZING. XS-S-M-L-XL-XXL
COLORS. BLACK

FLEXIBILITY **100%**
WARMTH **70%**
COMFORT **95%**

NEW



SEAFARER
BACKZIP

3.2

DETAILS

REF. 22251-5004
SIZING. XS-S-M-L-XL-XXL
COLORS. BLACK

FLEXIBILITY **100%**
WARMTH **75%**
COMFORT **95%**



SEAFARER
HYBRID

3.2

DETAILS

REF. 22251-5005
SIZING. XS-S-M-L-XL-XXL
COLORS. BLACK - PEWTER

FLEXIBILITY **100%**
WARMTH **70%**
COMFORT **95%**



Seafarer. 25



Groms

NEW



SEAFARER FRONTZIP

5.4.3

DETAILS

REF. **22251-2101**
 SIZING. 8-9 / 10-11 / 12-13 / 14-15 years
 COLORS. BLACK

FLEXIBILITY **90%**
 WARMTH **85%**
 COMFORT **95%**

NEW



SEAFARER FRONTZIP

4.3

DETAILS

REF. **22251-2102**
 SIZING. 8-9 / 10-11 / 12-13 / 14-15 years
 COLORS. BLACK

FLEXIBILITY **95%**
 WARMTH **80%**
 COMFORT **95%**



SEAFARER FRONTZIP

3.2

DETAILS

REF. **22251-2103**
 SIZING. 8-9 / 10-11 / 12-13 / 14-15 years
 COLORS. BLACK

FLEXIBILITY **100%**
 WARMTH **75%**
 COMFORT **95%**

THICKNESS REPARTITION

Men

Women

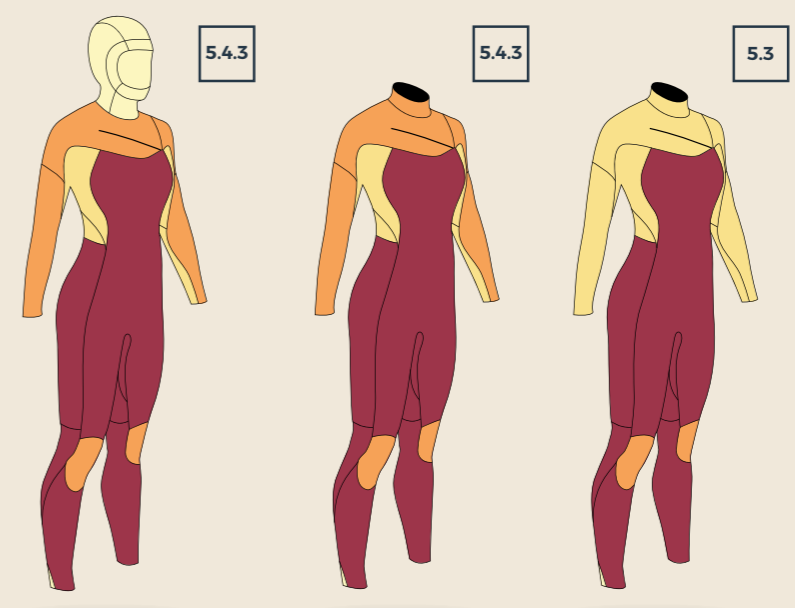
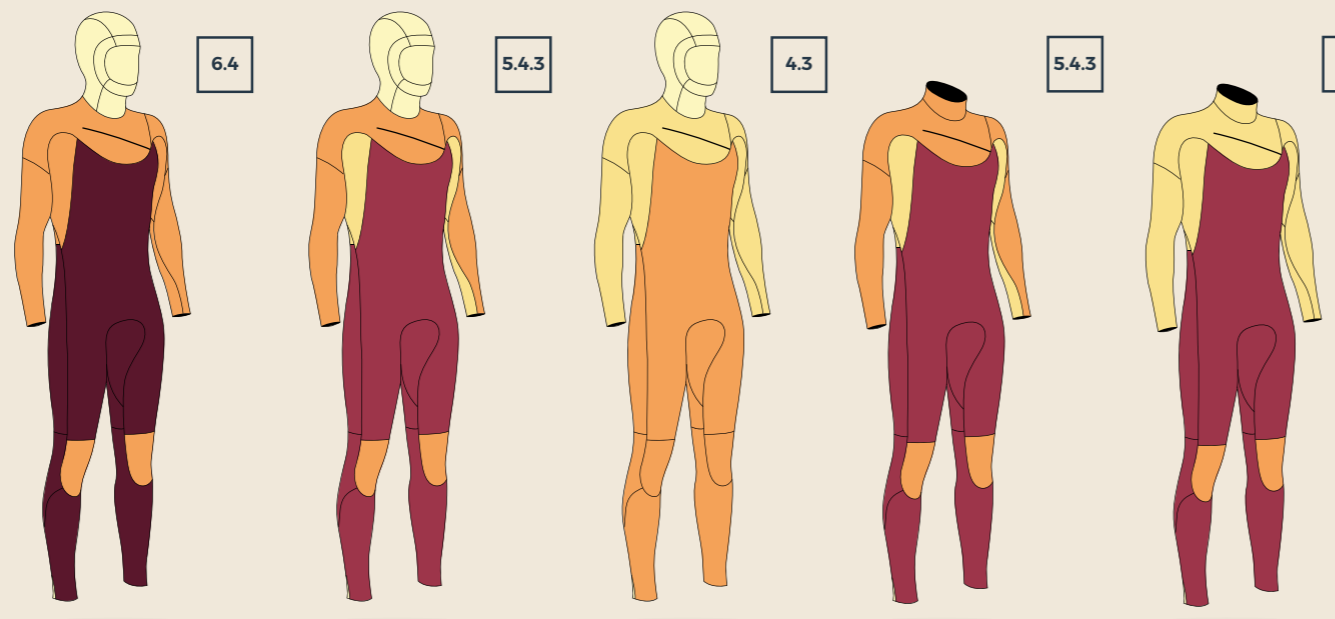

6 MM	50,7%				
5 MM		50,7%		54,8%	
4 MM	40,6%	33,2%	53,3%	35,9%	57,7%
3 MM		7,4%	37,9%	9,3%	42,3%
2 MM	8,8%	8,8%	8,8%		

6 MM			
5 MM	47,4%	50,3%	52,9%
4 MM	20,3%	26,5%	
3 MM	23,6%	23,2%	47,1%
2 MM	8,8%		

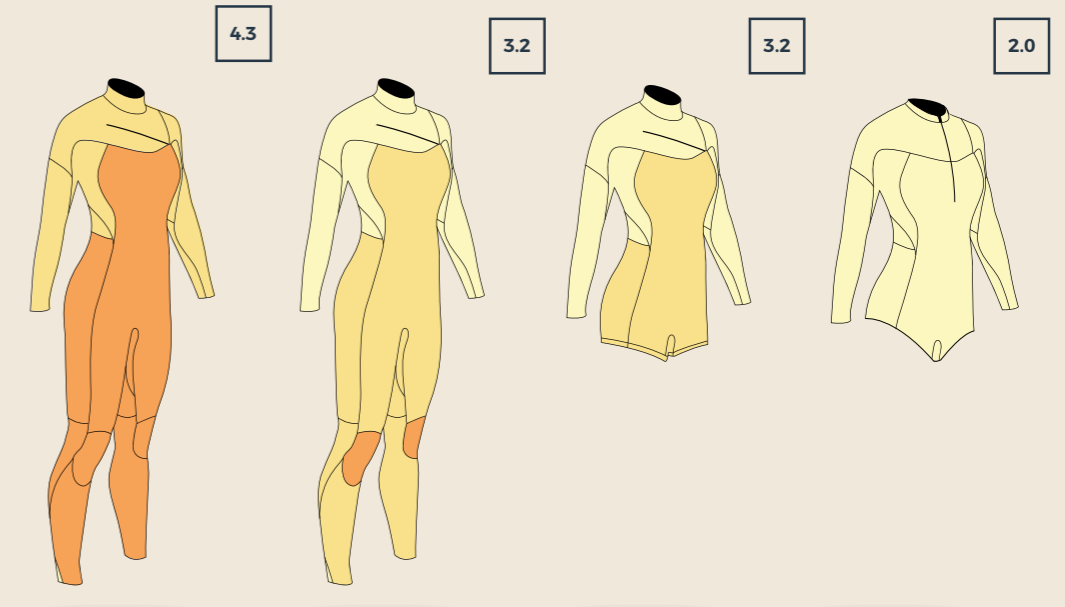
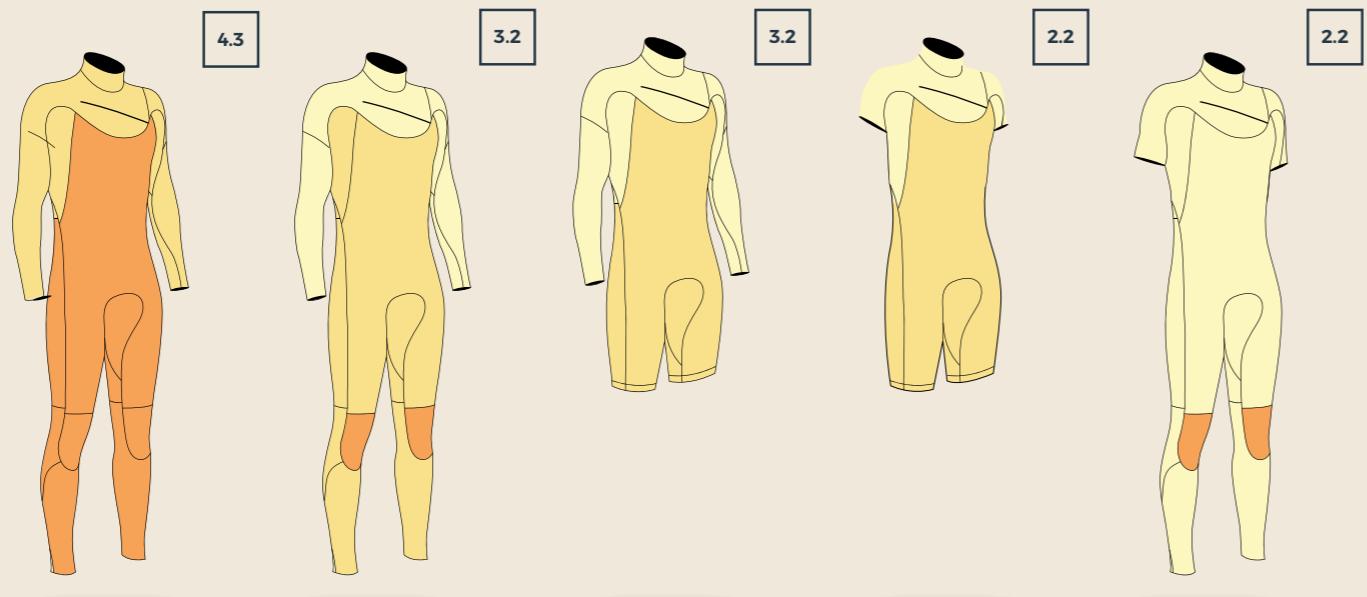

4 MM	57,7%	2,9%			
3 MM	42,3%	56,1%	50,1%	52,1%	1,7%
2 MM		40,9%	49,9%	47,9%	98,2%

4 MM	52,9%	2,6%	
3 MM	47,1%	51,6%	37,2%
2 MM		45,7%	62,8%
			100%

NEOPRENE ACCESSORIES

OVERVIEW

NEOPRENE ACCESSORIES

NEOPRENE ACCESSORIES



2.0 MM

MAGMA HOOD
Ref. 22241-0807
Sizes. S-M-L-XL
Colors. BLACK



2.0 MM

XTEND HOOD
Ref. 22241-0908
Sizes. S-M-L-XL
Colors. BLACK



2.0 MM

MAGMA CAP
Ref. 22231-1706
Sizes. S-M-L-XL
Colors. BLACK



3.0 MM

SEAFARER CAP
Ref. 22231-1804
Sizes. S-M-L-XL
Colors. BLACK



0.5 MM

MAGMA BASELAYER HOODED
Ref. 22231-1301
Sizes. XS-S-M-L-XL
Colors. BLACK



0.5 MM

MAGMA BASELAYER
Ref. 22231-1302
Sizes. XS-S-M-L-XL
Colors. BLACK



0.5 MM

X10D BASELAYER HOODED
Ref. 22221-1401
Sizes. XS-S-M-L-XL
Colors. BLACK



5 MM

MAGMA LOBSTER GLOVE
Ref. 22241-0609
Sizes. S-M-L-XL
Colors. BLACK



2.5 MM

MAGMA LOBSTER GLOVE
Ref. 22241-0607
Sizes. S-M-L-XL
Colors. BLACK



2.5 MM

MAGMA OPEN PALM
Ref. 22231-0608
Sizes. S-M-L-XL
Colors. BLACK



2.5 MM

MAGMA GLOVES
Ref. 22231-0607
Sizes. S-M-L-XL
Colors. BLACK



2.0 MM

X10D NEO TOP
Ref. 22221-1107
Sizes. XS-S-M-L-XL
Colors. BLACK



1.0 MM

SEAFARER NEO TOP
Ref. 22221-1208
Sizes. XS-S-M-L-XL
Colors. CASCADE / BLACK



7.0 MM

MAGMA BOOTS ROUND TOE
Ref. 22251-1501
Sizes.
[EU] 36-37.5-39-40-41-42-43-44-45-46
[US] 4-5-6.5-7-8-8.5-9.5-10-11-12
Colors. BLACK



5.0 MM

MAGMA BOOTS ROUND TOE
Ref. 22251-1502
Sizes.
[EU] 36-37.5-39-40-41-42-43-44-45-46
[US] 4-5-6.5-7-8-8.5-9.5-10-11-12
Colors. BLACK



2.0 MM

XTEND LOBSTER GLOVE
Ref. 22241-0708
Sizes. S-M-L-XL
Colors. BLACK



2.0 MM

X10D GLOVES
Ref. 22221-0708
Sizes. S-M-L-XL
Colors. BLACK



5.0 MM

MAGMA BOOTS SPLIT TOE
Ref. 22251-1102
Sizes.
[EU] 36-37.5-39-40-41-42-43-44-45-46
[US] 4-5-6.5-7-8-8.5-9.5-10-11-12
Colors. BLACK



3.0 MM

X10D BOOTS ROUND TOE
Ref. 22251-1604
Sizes.
[EU] 36-37.5-39-40-41-42-43-44-45-46
[US] 4-5-6.5-7-8-8.5-9.5-10-11-12
Colors. BLACK



3.0 MM

X10D BOOTS SPLIT TOE
Ref. 22251-1204
Sizes.
[EU] 36-37.5-39-40-41-42-43-44-45-46
[US] 4-5-6.5-7-8-8.5-9.5-10-11-12
Colors. BLACK



CAR SEAT COVER
Ref. 22226-0400
Sizes. ONE SIZE
Colors. BLACK



CAR SEAT COVER
Ref. 22246-0401
Sizes. ONE SIZE
Colors. BLACK-GREEN



Neoprene.

ACCESSORIES

25



MAGMA BASELAYER 0.5 mm
HOODED

DETAILS

REF.	22231-1301
SIZING.	XS-S-M-L-XL
COLORS.	BLACK

FEATURES

- Magma +
- Waterproof
- Glideskin
- Stretch



MAGMA BASELAYER 0.5 mm

DETAILS

REF.	22231-1302
SIZING.	XS-S-M-L-XL
COLORS.	BLACK

FEATURES

- Magma +
- Stretch
- Waterproof



X10D BASELAYER 0.5 mm
HOODED

DETAILS

REF.	22221-1401
SIZING.	XS-S-M-L-XL
COLORS.	BLACK

FEATURES

- X10D Jersey
- Stretch
- Waterproof



X10D NEO TOP 2.0 mm
SUMMER SESSION

DETAILS

REF.	22221-1107
SIZING.	XS-S-M-L-XL
COLORS.	BLACK

FEATURES

- 3D designed
- Flatlock
- Elastic Thightening



SEAFARER NEO TOP 1.0 mm
SUMMER SESSION

DETAILS

REF.	22221-1208
SIZING.	XS-S-M-L-XL
COLORS.	CASCADE / BLACK

FEATURES

- 3D designed
- Flatlock



CAR SEAT COVER

DETAILS

REF.	22226-0400 / 22246-0401
SIZING.	ONE SIZE
COLORS.	BLACK / BLACK-GREEN

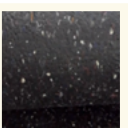

- Outside jersey 100% recycled.
- Inside neoprene 100% recycled.

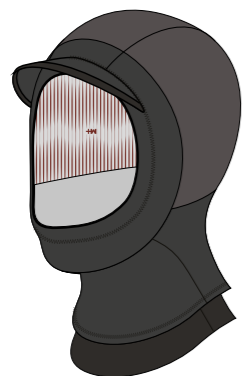

MAGMA HOOD
COLD SESSION

2.0 mm

DETAILS

REF.	22241-0807
SIZING.	S-M-L-XL
COLORS.	BLACK



XTEND HOOD
COLD SESSION

2.0 mm

DETAILS

REF.	22241-0908
SIZING.	S-M-L-XL
COLORS.	BLACK

FEATURES

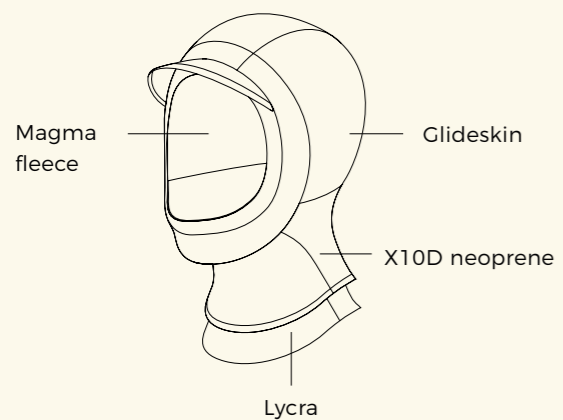

MAGMA HOOD

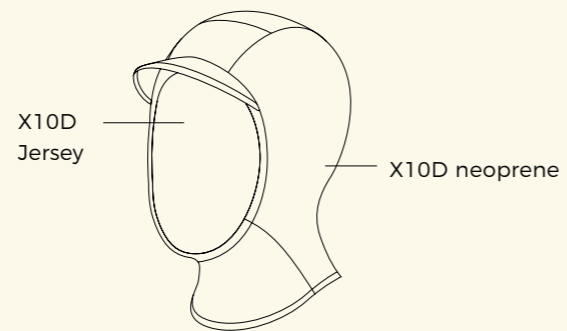

XTEND HOOD





MAGMA CAP
COLD SESSION

2.0
mm

DETAILS

REF.	22231-1706
SIZING.	S-M-L-XL
COLORS.	BLACK



SEAFARER CAP
COLD SESSION

3.0
mm

DETAILS

REF.	22231-1804
SIZING.	S-M-L-XL
COLORS.	BLACK

FEATURES

MAGMA CAP

- Magma Plus fleece
- Wind/waterproof Glideskin

SEAFARER CAP

- X10D neoprene
- X10D Jersey



NEW

MAGMA BOOTS
ROUND TOE

7.0 mm

DETAILS

REF. **22251-1501**

SIZING. [EU] 36-37,5-39-40-41-42-43-44-45-46
[US] 4-5-6,5-7-8-8,5-9,5-10-11-12

COLORS. BLACK

FEATURES

- Rubber sidewalls ensure the foot is locked and maintained.
- MAGMA+ Fleece provides warmth and fast drying.



NEW

MAGMA BOOTS
ROUND TOE

5.0 mm

DETAILS

REF. **22251-1502**

SIZING. [EU] 36-37,5-39-40-41-42-43-44-45-46
[US] 4-5-6,5-7-8-8,5-9,5-10-11-12

COLORS. BLACK

FEATURES

- Rubber sidewalls ensure the foot is locked and maintained.
- MAGMA+ Fleece provides warmth and fast drying.

FEATURES



MAGMA BOOTS

X10D BOOTS



NEW

MAGMA BOOTS
SPLIT TOE

5.0 mm

DETAILS

REF. **22251-1102**

SIZING. [EU] 36-37,5-39-40-41-42-43-44-45-46
[US] 4-5-6,5-7-8-8,5-9,5-10-11-12

COLORS. BLACK

FEATURES

- Rubber sidewalls ensure the foot is locked and maintained.
- MAGMA+ Fleece provides warmth and fast drying.



NEW

MAGMA BOOTS
ROUND TOE

3.0 mm

DETAILS

REF. **22221-1604**

SIZING. [EU] 36-37,5-39-40-41-42-43-44-45-46
[US] 4-5-6,5-7-8-8,5-9,5-10-11-12

COLORS. BLACK

FEATURES

- Rubber sidewalls ensure the foot is locked and maintained.
- A donut shaped cuff prevents water from getting in
- X10D jersey keeps boots light.



NEW

X10D BOOTS
SPLIT TOE

3.0 mm

DETAILS

REF. **22221-1204**

SIZING. [EU] 36-37,5-39-40-41-42-43-44-45-46
[US] 4-5-6,5-7-8-8,5-9,5-10-11-12

COLORS. BLACK

FEATURES

- Rubber sidewalls ensure the foot is locked and maintained.
- A donut shaped cuff prevents water from getting in
- X10D jersey keeps boots light.

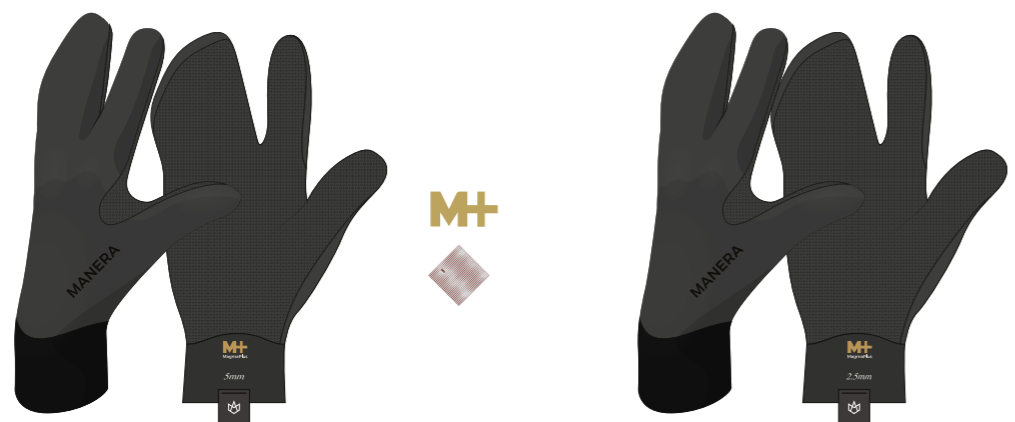

**MAGMA
LOBSTER GLOVE**
COLD SESSION

5.0 mm

DETAILS

REF. 22241-0609
SIZING. S-M-L-XL
COLORS. BLACK

FEATURES

- Magma +
- Waterproof
- Glideskin
- Stretch



**MAGMA
LOBSTER GLOVE**
COLD SESSION

2.5 mm

DETAILS

REF. 22241-0607
SIZING. S-M-L-XL
COLORS. BLACK

FEATURES

- Magma +
- Waterproof
- Glideskin
- Stretch

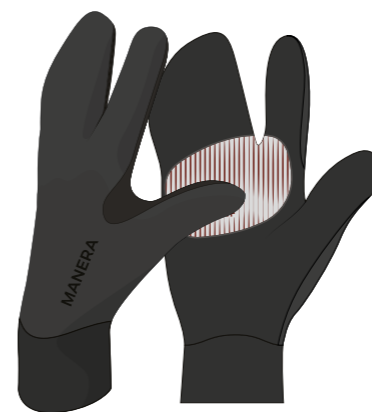

**MAGMA
OPEN PALM**
COLD SESSION

2.5 mm

DETAILS

REF. 22231-0608
SIZING. S-M-L-XL
COLORS. BLACK

FEATURES

- Magma +
- Waterproof
- Glideskin
- Stretch



**XTEND
LOBSTER GLOVE**
COLD SESSION

2.0 mm

DETAILS

REF. 22241-0708
SIZING. S-M-L-XL
COLORS. BLACK

FEATURES

- X10D Jersey
- Waterproof
- Stretch

FEATURES

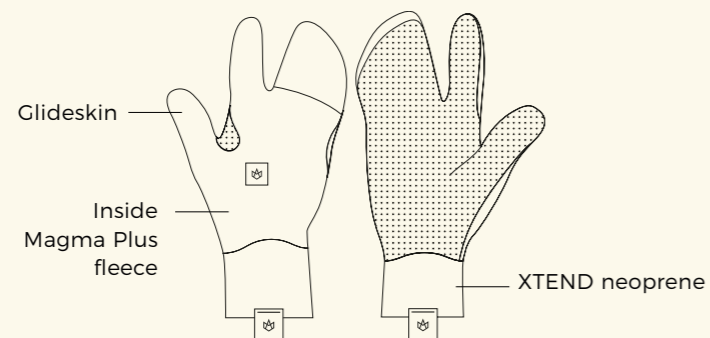

MAGMA GLOVE

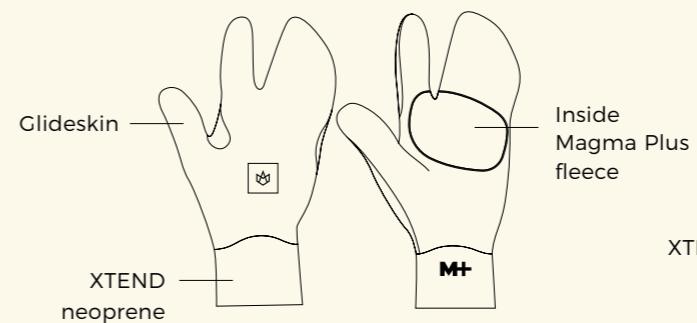

MAGMA OPEN PALM

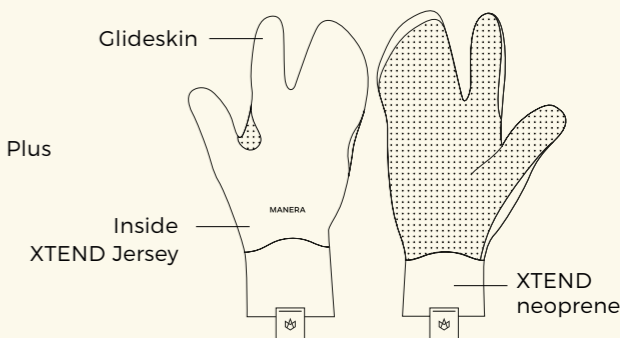

X10D GLOVE



MAGMA GLOVE
COLD SESSION

2.5 mm

DETAILS

REF. 22231-0607
SIZING. S-M-L-XL
COLORS. BLACK

FEATURES

- Magma +
- Glideskin
- Waterproof
- Stretch



X10D GLOVE
COLD SESSION

2.0 mm

DETAILS

REF. 22221-0708
SIZING. S-M-L-XL
COLORS. BLACK

FEATURES

- X10D Jersey
- Waterproof
- Stretch



FEATURES

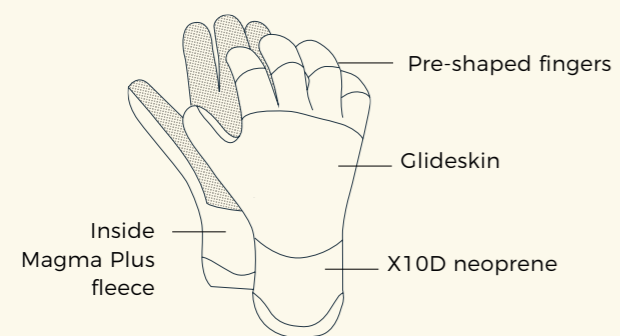

MAGMA GLOVE

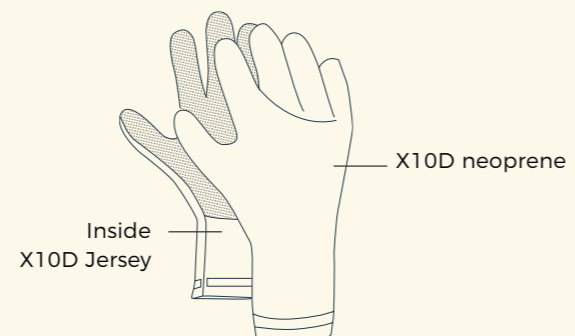

X10D GLOVE

HARNESSES

OVERVIEW

HALO HARNESSES

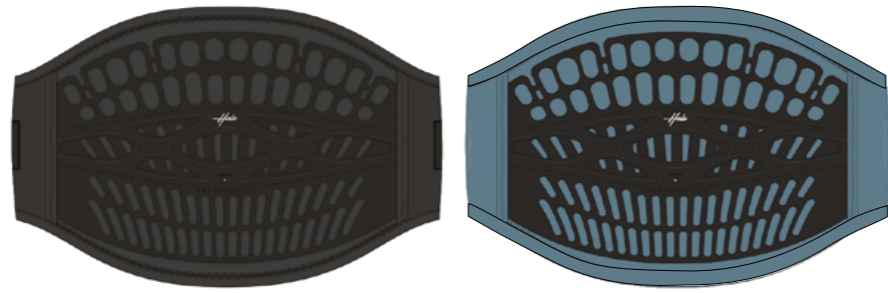

BLACK

STEEL BLUE

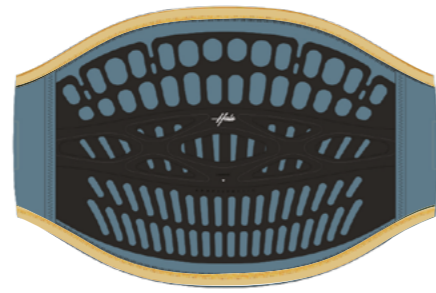

STORMY

NEW

HALO V2

Ref. 22242-0600
 Sizes. XS-S-S+M-M+L-XL
 Colors. BLACK / STEEL BLUE / STORMY

HARDSHELL	100%
LIGHTNESS	100%
DURABILITY	100%

EXO HARNESSES

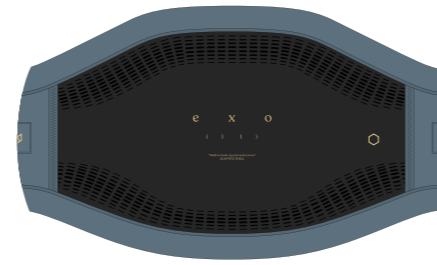

MIRAGE

EXO

Ref. 22232-0200
 Sizes. XS-S-S+M-M+L-XL
 Colors. MIRAGE

STIFFNESS	70%
LIGHTNESS	80%
DURABILITY	90%

LIFT HARNESSES



BLACK

LIFT WING HARNESSES

Ref. 22242-0301
 Sizes. XXS-XS--S-M-L-XL-XXL
 Colors. BLACK

LIGHTNESS	100%
DURABILITY	90%
COMFORT	90%

ECLIPSE HARNESSES



BLACK



LARGO

ECLIPSE

Ref. 22232-0100
 Sizes. XS-S-S+M-M+L-XL
 Colors. BLACK / LARGO

HARDSHELL	70%
LIGHTNESS	90%
DURABILITY	90%

HARNESSES ACCESSORIES



NEW HALO - PIVOT INTER (x1) V2
 Ref. 22242-5006
 Sizes. UNIQUE SIZE
 Colors. BLACK



NEW HALO - ADAPTIVE SKIN V2
 Ref. 22222-5009
 Sizes. XS/S/M - L/XL
 Colors. BLACK



HALO - HARDSHELL
 Ref. 22222-5005
 Sizes. XS-S-M-L-XL
 Colors. BLACK



HALO - SOFT SPARE PART
 Ref. 22222-5003
 Sizes. XS-S-M-L-XL
 Colors. BLACK



HALO - STRAP & PLASTIC BUCKLE
 Ref. 22242-5004
 Sizes. UNIQUE SIZE
 Colors. BLACK



NEW HALO - PIVOT EXTER (x1) V2
 Ref. 22242-5007
 Sizes. UNIQUE SIZE
 Colors. BLACK



HALO - M5 SCREW + NUT FOR AXIS
 Ref. 22242-5008
 Sizes. UNIQUE SIZE
 Colors. SST



NEW HALO - SECURITY BELT (X2)
 Ref. 22242-5010
 Sizes. XS-S-M-L-XL-XXL
 Colors. BLACK



ARC - SPREADERBAR
 Ref. 22232-4001
 Sizes. 24-28-32
 Colors. BLACK



NEW ARC - EVA THERMOFORM
 Ref. 22232-4006
 Sizes. 24-28-32
 Colors. BLACK



KITE KNIFE
 Ref. 22222-5001
 Sizes. UNIQUE SIZE
 Colors. RED



ARC - SST HOOK (x1)
 Ref. 22232-4003
 Sizes. UNIQUE SIZE
 Colors. SST



ARC - BUCKLES (x2)
 Ref. 22232-4004
 Sizes. UNIQUE SIZE
 Colors. BLACK



ARC - SLIDING ROPE
 Ref. 22232-4002
 Sizes. 24-28-32
 Colors. BLACK



ARC - FLAT SCREW
 Ref. 22232-4005
 Sizes. UNIQUE SIZE
 Colors. SST



WING HARNESSES LINE
 Ref. 22242-3001
 Sizes. UNIQUE SIZE
 Colors. BLACK



WING HOOK
 Ref. 22242-3000
 Sizes. UNIQUE SIZE
 Colors. BLACK

HOW TO CHOOSE

HARNESSES

EXO

(Size M)

WEIGHT 1.75KG

HEIGHT 27.6CM

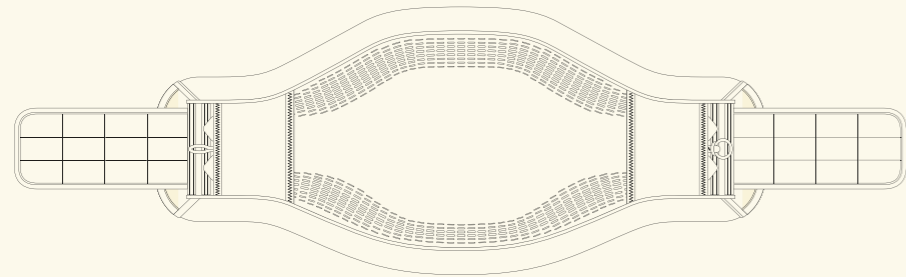

HARDSHELL

70%

LIGHTNESS

80%

DURABILITY

90%

PROFILE

High

ECLIPSE

(Size M)

WEIGHT 1.55KG

HEIGHT 27CM

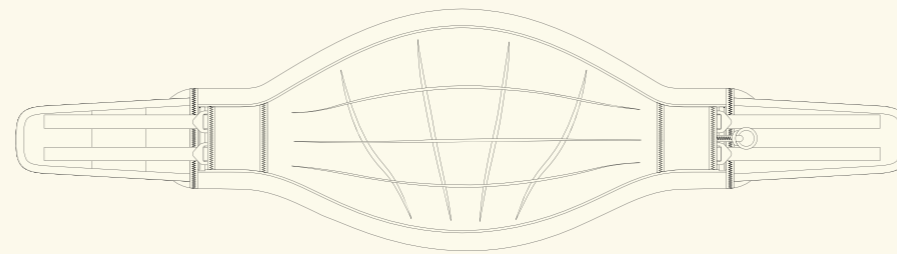

HARDSHELL

70%

LIGHTNESS

90%

DURABILITY

90%

PROFILE

Medium

HALO

(Size M)

WEIGHT 1.35KG

HEIGHT 26CM

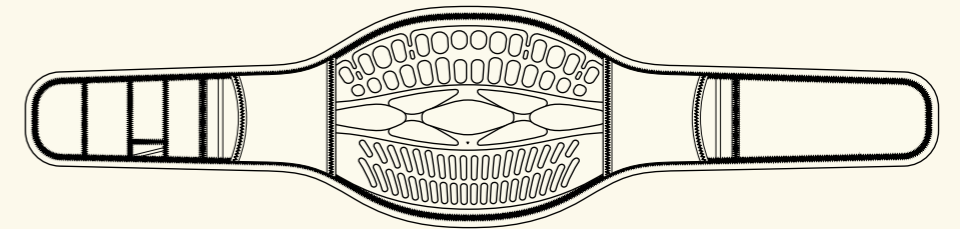

HARDSHELL

100%

LIGHTNESS

100%

DURABILITY

100%

PROFILE

Low

HARNESSES OUTLINES

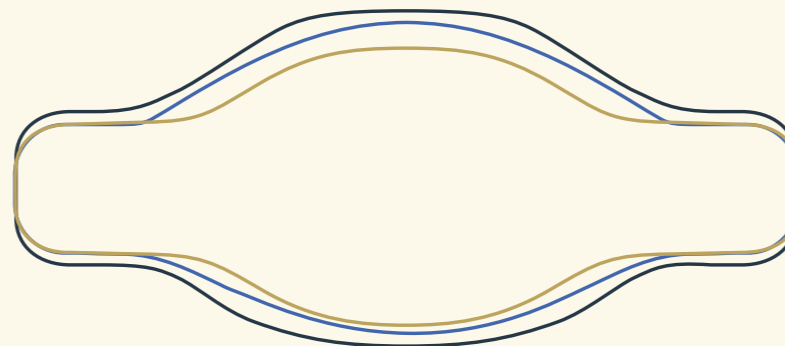

— Exo

— Eclipse

— Halo

Halo.

HARNESSES



Support



BLACK



HALO HARNESSES V2

DETAILS

REF. **22242-0600**
SIZING. XS-S-S+-M-M+-L-XL
COLORS. BLACK / STORMY / STEEL BLUE

HARDSHELL **100%**
LIGHTNESS **100%**
DURABILITY **100%**

STORMY

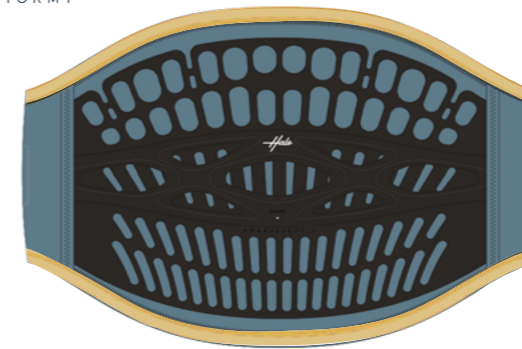

STEEL BLUE

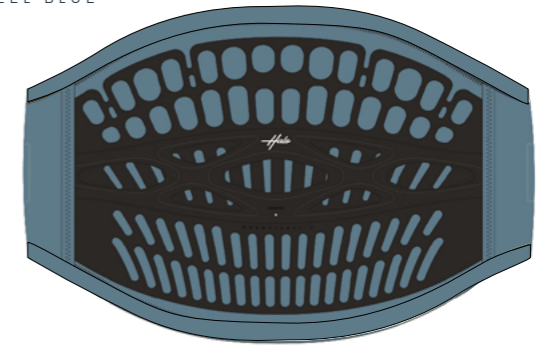

THE HALO

A NEW GENERATION OF HARNESS

HARDSHELL	100%
LIGHTNESS	100%
DURABILITY	100%
PROFILE	Low

ADAPTIVE SHELL

A FEW YEARS AGO, WE STARTED THE "ADAPTIVE SHELL" PROJECT, WHICH GOAL WAS TO REINVENT THE KITE HARNESS. THIS PATENTED* TECHNOLOGY IS CHARACTERIZED BY TWO MAIN FUNCTIONS:

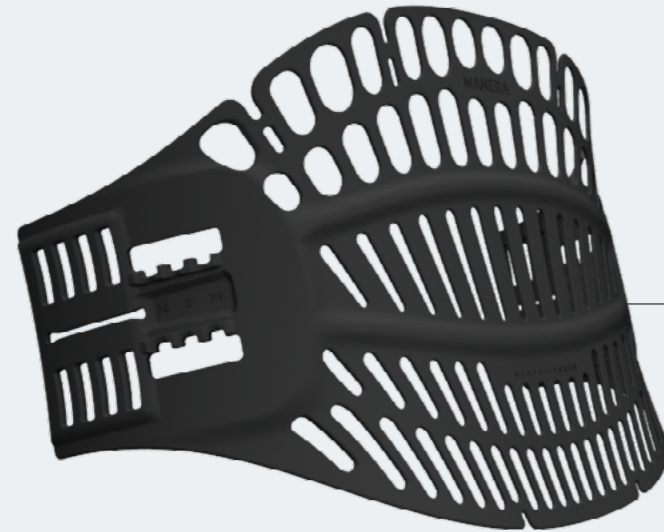

ADAPTIVE SKIN

- is a backing strip made out of flexible material that allows maximum adaptability and freedom of movement to the user.
- It is directly in contact with the body, its function is to provide comfort to the user.

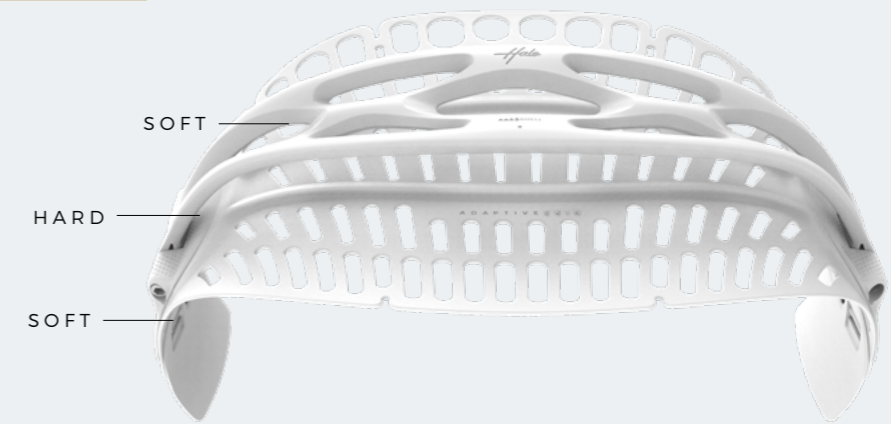

HARDSHELL

- is a rigid arch preventing the harness from folding due to the kite's high loads, and therefore squeezing the user's sides.
- It is not in contact with the user, its function is to sustain all the mechanical forces that the harness endures.

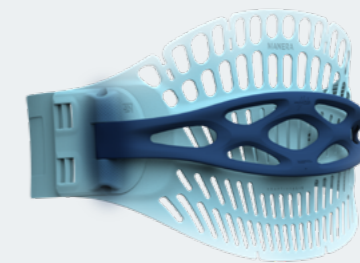

KITE KNIFE
INCLUDED

ASSEMBLING THE ADAPTIVE SKIN AND THE HARD SHELL TOGETHER RESULTS IN THE BEST HARNESS WE'VE EVER MADE. IT PERFECTLY ADAPTS TO YOUR MORPHOLOGY AND TO YOUR MOVEMENTS, WHILE OFFERING AN UNMATCHED SUPPORT THANKS TO AN INNOVATIVE LOADS MANAGEMENT.

HARDSHELL	100%
LIGHTNESS	100%
DURABILITY	100%
PROFILE	Low

THE HALO

A NEW GENERATION OF HARNESS

ARC SPREADERBAR



TECHNOLOGIES



1 CLIP SYSTEM

- The ARC easy-to-clip system is locked once tightened, which provides a precise and smooth riding without improper movements.



2 SST CORE

- The ARC is built with a robust Stainless-Steel core that is able to withstand 800kg loads, which is much higher than the standard kite requirements.



3 TUCKFLAP 2.0

- Once inserted and locked into the harness, not only they prevent the harness from going up, but they also have an anti-compression function preventing the loads of the kite to squeeze the harness around your hips.

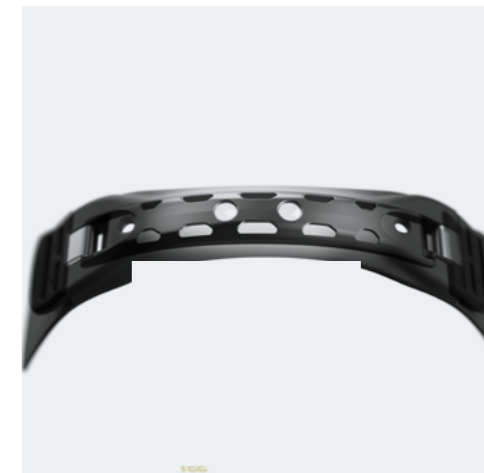

4 HOOK / SLIDING

- The ARC is easily convertible between standard hook and a sliding rope.

Eclipse.

HARNESSES



Support



ADAPTIVE SHELL

ECLIPSE

BLACK



LARGO



ECLIPSE HARNESSES

DETAILS

REF.	22232-0100
SIZING.	XS-S-S+M-M+L-XL
COLORS.	BLACK / LARGO

HARDSHELL	70%
LIGHTNESS	90%
DURABILITY	90%

ECLIPSE HARNESS

KEY FEATURES

HARDSHELL	70%
LIGHTNESS	90%
DURABILITY	90%
PROFILE	Medium

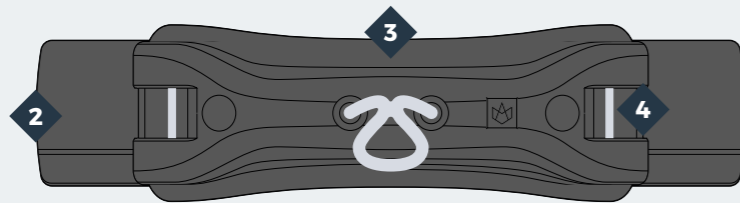
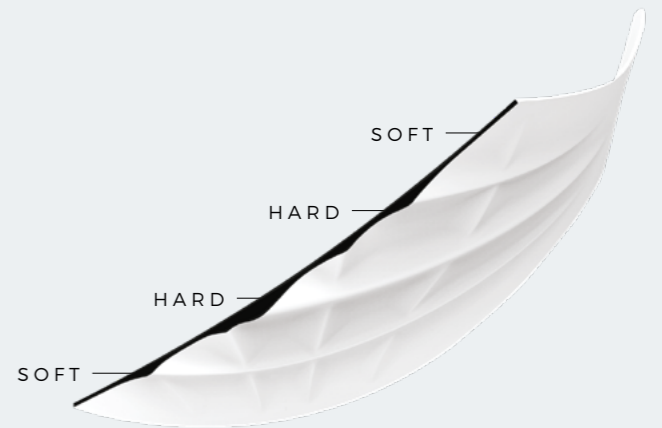

R&D HARNESS

Having worked on ergonomic designs for a while, our goal was to push our frame concept to more stiffness, allowing a better support of the back & a lower fit.

But something 100% hard was not an option: Our back needs some adaptability & human morphology is unique.

So here comes the ECLIPSE, a skilful balance between stiffness & flex that brings support where you need it and the freedom to move the way you want.

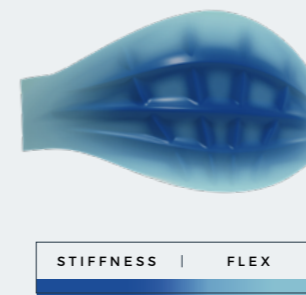

ADAPTIVE SHELL

- The Adaptive Shell stiffness shades from hard in the center area to softer on the edges
- The stiff center-belt prevents the harness from folding and compressing your body while preserving a good lumbar support
- The softer outline preserves intuitive mobility and adaptability
- It results in a shell that is forgiving where you need flex and stiff where you want support

Technologies



1 GEL FOAM

- The gel foam disperses pressure evenly & efficiently to provide a "pillow comfort", much appreciated during long sessions
- It creates a different sense of feeling while riding as it moves along with your movements, therefore the contact with the harness is more intuitive & it prevents any rash or rubbing discomfort



2 TUCK FLAP

- Flaps are inserted into the harness, they are compressed and locked when straps are tightened
- Stiffen the connection between spreader bar & harness & prevent it from riding up

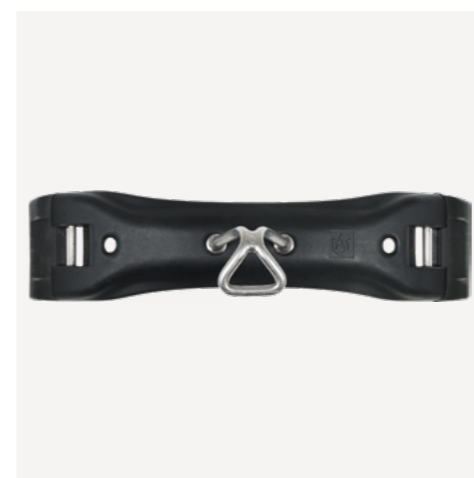

3 ARC SPREADER BAR

- ECLIPSE & EXO are now delivered with our innovative ARC spreaderbar



4 DOWN HOLD SYSTEM

- The spreader bar has an asymmetrical attachment that distributes the forces downward
- Secured in its original position, the hook does not ride back up

Exo.

HARNESS



Comfort

e x o



EXO HARNESS

DETAILS

REF. 22212-0200
SIZING. XS-S-S+-M-M+-L-XL
COLORS. MIRAGE

HARDSHELL 70%
LIGHTNESS 80%
DURABILITY 90%

EXO HARNESS

KEY FEATURES

HARDSHELL	70%
LIGHTNESS	80%
DURABILITY	90%
PROFILE	High

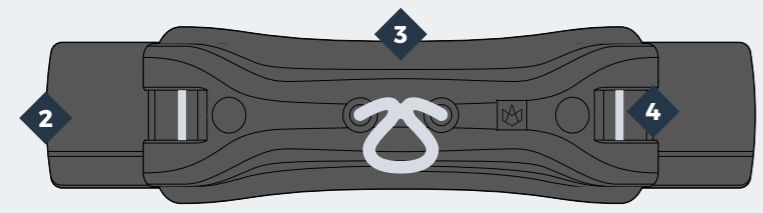
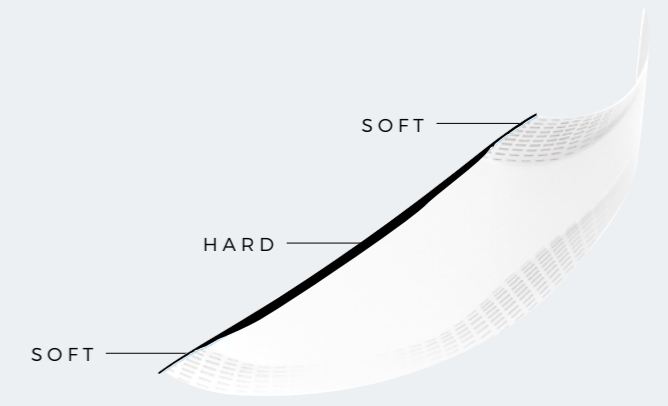

R&D HARNESS

It is difficult to improve upon a harness like the EXO, but we learned a lot by developing the ECLIPSE and so we used this experience to redesign our top harness.

We've applied Adaptive shell technology to our EXO model to give it better support, improved weight and durability. The EXO uses a more rigid frame incorporating different levels of stiffness.

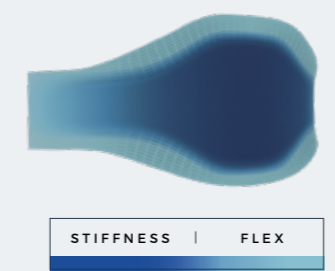

ADAPTIVE SHELL

- The Adaptive Shell stiffness shades from hard in the center area to softer on the edges
- The stiff center-belt prevents the harness from folding and compressing your body while preserving a good lumbar support
- The softer outline preserves intuitive mobility and adaptability
- It results in a shell that is forgiving where you need flex and stiff where you want support

Technologies



- 1 SINGLE FOAM**
- Thermoformed one-piece foam backing
 - Much lighter than multiple foam layouts used in some harnesses
 - More durable as there are less parts to be glued or stitched together



- 2 TUCK FLAP**
- Flaps are inserted into the harness, they are compressed and locked when straps are tighten
 - Stiffen the connection between spreader bar & harness & prevent it from riding up



- 3 ARC SPREADER BAR**
- ECLIPSE & EXO are now delivered with our innovative ARC spreaderbar



- 4 DOWN HOLD SYSTEM**
- The spreader bar has an asymmetrical attachment that distributes the forces downward
 - Secured in its original position, the hook does not ride back up

Lift.

HARNESSES



Lightness

LiftHarness

WNG Lite harness.



LIFT WING HARNESSES

DETAILS

REF.	22242-0301
SIZING.	XXS-XS--S-M-L-XL-XXL
COLORS.	BLACK

LIGHTNESS	100%
DURABILITY	90%
COMFORT	90%

LIFT WING HARNESS

KEY FEATURES

LIGHTNESS	100%
DURABILITY	90%
CONFORT	90%

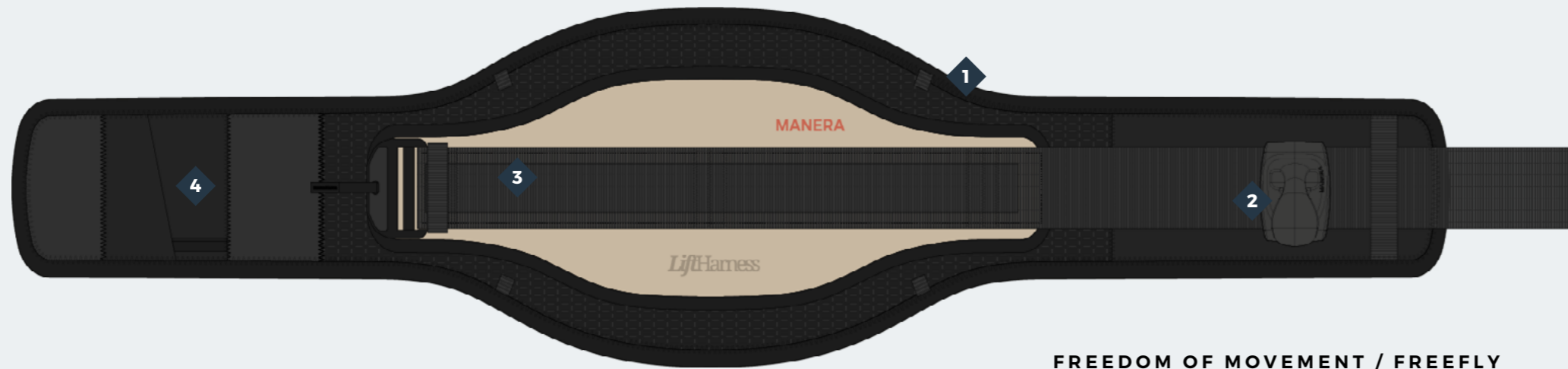

LIFT WING HARNESS

LIFT "lift", noun: getting a free ride as a passenger.

For us at MANERA, a wing harness is there to go unnoticed when freeflying while providing the necessary support to go back upwind.

That's why we have developed a light and adaptable harness with a low profile. See it as a "lift" back to the top of the downwind slope!

FREEDOM OF MOVEMENT / FREEFLY

The low profile, soft outline and light construction of the LIFT provides a "like you're wearing nothing" feeling.

ADAPTIVE SHELL / LOW PROFILE

Being significantly smaller than a standard kite harness, the LIFT lays comfortably on your lower back.

It features an adaptive shell inside that still provides the necessary support.

Technologies

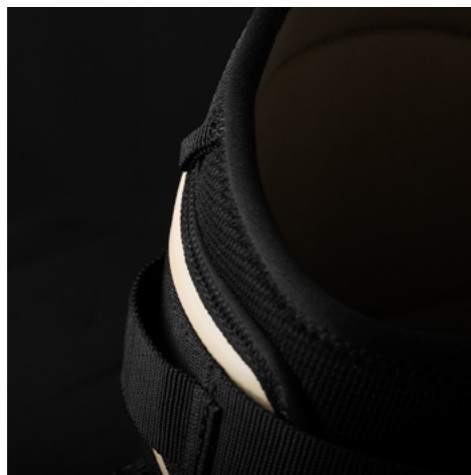

1 FREE TO FREEFLY

- The low profile, soft outline and light construction of the LIFT provide a "like you're wearing nothing" feeling



2 SLIDING HOOK

- The hook can slide around the front strap, allowing you to move it left or right before laying on your board.



3 LEAH ATTACHMENTS

- The harness features many strong attachments options for your wing and board leashes.



4 KITE KNIFE POCKET

- An easily accessible knife can be a life saver if you (or your friend) get stuck in kite lines or in a fishing net.

Harness.

ACCESSORIES



HALO STRAP & PLASTIC BUCKLE

DETAILS

REF. **22222-5004**
 SIZING. UNIQUE
 COLORS. BLACK



HALO HARDSHELL

DETAILS

REF. **22222-5005**
 SIZING. XS-S-M-L-XL
 COLORS. BLACK



NEW
HALO ADAPTIVE SKIN V2

DETAILS

REF. **22242-5009**
 SIZING. XS-S-M-L-XL
 COLORS. BLACK



HALO SOFT SPAREPART (x1)

DETAILS

REF. **22222-5003**
 SIZING. UNIQUE
 COLORS. BLACK



NEW
HALO SECURITY BELT

DETAILS

REF. **22242-5010**
 SIZING. XS-S-M-L-XL-XXL
 COLORS. BLACK



WING HARNESS LINE

DETAILS

REF. **22242-3001**
 SIZING. UNIQUE
 COLORS. BLACK



KITE KNIFE

DETAILS

REF. **22222-5001**
 SIZING. UNIQUE
 COLORS. RED



NEW
HALO PIVOT EXTER V2 (x1)

DETAILS

REF. **22242-5006**
 SIZING. UNIQUE
 COLORS. BLACK



NEW
HALO PIVOT INTER V2 (x1)

DETAILS

REF. **22242-5007**
 SIZING. UNIQUE
 COLORS. BLACK



HALO M5 SCREW & M5 NUT FOR AXIS

DETAILS

REF. **22242-5008**
 SIZING. UNIQUE
 COLORS. SST



ARC FLAT SCREW

DETAILS

REF. **22232-4005**
 SIZING. UNIQUE
 COLORS. SST



WING HOOK

DETAILS

REF. **22242-3000**
 SIZING. UNIQUE
 COLORS. BLACK



ARC SPREADERBAR

DETAILS

REF. **22232-4001**
 SIZING. 24CM - 28CM - 32CM
 (XS-S) - (M-L) - (XL-XXL)
 COLORS. BLACK



ARC SLIDING ROPE

DETAILS

REF. **22232-4002**
 SIZING. 24CM - 28CM - 32CM
 (XS-S) - (M-L) - (XL-XXL)
 COLORS. BLACK



ARC SST HOOK (x1)

DETAILS

REF. **22232-4003**
 SIZING. UNIQUE
 COLORS. SST



ARC BUCKLES (x2)

DETAILS

REF. **22232-4004**
 SIZING. UNIQUE
 COLORS. BLACK

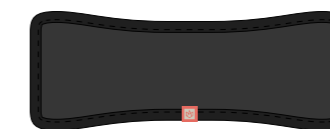

NEW
ARC EVA THERMOFORM

DETAILS

REF. **22232-4006**
 SIZING. 24-28-32
 COLORS. BLACK

BOARDBAGS

OVERVIEW

DAY BAGS

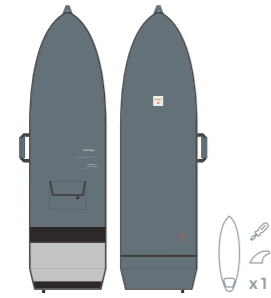

SURF
5'3 / 5'6 / 6'0
Ref. 22223-0104 / 22223-0105
22223-0106
Sizes. 5'3 -163x53CM
5'6 -175x54CM
6'0 -188x58CM
Weight. 1KG
Colors. SLATE

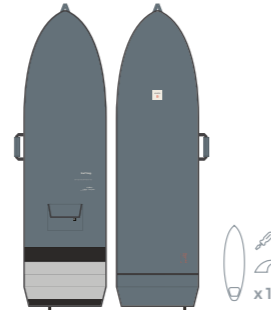

SURF
6'5 / 7'2
Ref. 22223-0107 / 22223-0108
22223-0106
Sizes. 6'5 -200x60CM
7'2 -220x66CM
Weight. 1KG
Colors. SLATE

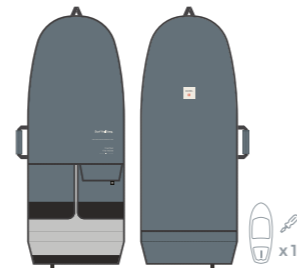

SURF FOIL
4'4 / 4'8
Ref. 22223-0109 / 22223-0110
22223-0110
Sizes. 4'4 -135x60CM
4'8 -145x65CM
Weight. 1KG
Colors. SLATE

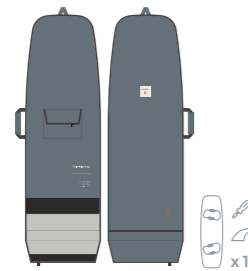

TWIN-TIP
Ref. 22223-0101
22223-0101
Sizes. 5'0 -145x50CM
Weight. 1KG
Colors. SLATE

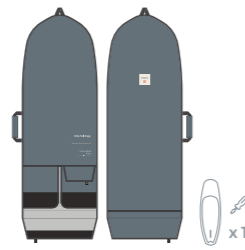

KITEFOIL
Ref. 22223-0103
22223-0103
Sizes. 4'3 -130x50CM
5'0 -145x60CM
Weight. 1KG
Colors. SLATE

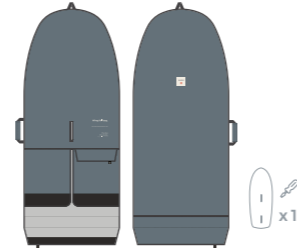

WING
5'0 / 5'5 / 6'0
Ref. 22223-0111 / 22223-0112
22223-0113
Sizes. 5'0 -156x70CM
5'5 -170x75CM
6'0 -185x85CM
Weight. 1KG
Colors. SLATE

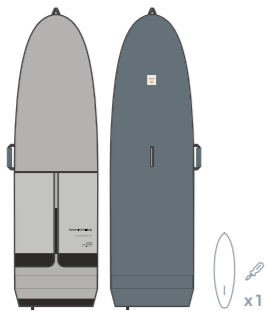

NEW
SUP DOWNWIND
6'7 / 7'0 / 7'5 / 8'0
Ref. 22243-0114 / 22243-0115
22243-0116 / 22243-0117
Sizes. 6'7 - 207x65CM / 7'0 - 217x68CM
7'5 - 230x70CM / 8'0 - 240x72CM
Weight. 1KG
Colors. SLATE

TRAVEL BAGS



747 WHEELS
Ref. 22233-0203
22233-0203
Sizes. 155x32x47CM
Weight. 4.7KG
Colors. BLACK



747 WHEELS
Ref. 22233-0203
22233-0203
Sizes. 175x30x54CM
190x30x54CM
220x30x54CM
Weight. 5.5KG
Colors. BLACK



FOIL WHEELS
5'0 / 5'5 / 6'0
Ref. 22233-0206
22233-0206
Sizes. 5'0 - 160x64x24CM
5'5 - 170x75x24CM
6'0 - 180x85x24CM
Weight. 2.7KG
Colors. BLACK



BIGGIE 160L
Ref. 22233-0205
22233-0205
Sizes. 92 x 58 x 34CM
Weight. 2.15KG
Colors. BLACK

FOIL BAGS

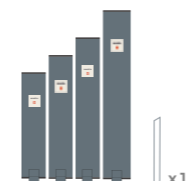

MAST COVER
Ref. 22223-0301
22223-0301
Sizes. 65 / 75 / 85 / 95 / 105CM
Colors. SLATE

BACKPACKS



DUFFLE BAG 45L
Ref. 22233-0401
22233-0401
Sizes. 65 x 30 x 24CM
Colors. BLACK



DAY BAG 30L
Ref. 22233-0402
22233-0402
Sizes. 73 (53 rolled) x 31 x 19CM
Colors. BLACK

Travelbags.

25



747 WHEELS

155X32X47CM

DETAILS

REF.	22233-0203
SIZING.	155x32x47CM
WEIGHT.	4.7KG
COLORS.	BLACK

FEATURES

- Premium 600D Polyester fabric
- Upper waterproof pocket
- High quality wheels
- Inside mesh pockets
- 4 reinforced handles
- Inside tightening straps
- 8mm protection foam
- Bottom reinforcement
- 10mm High density protection foam
- Inside stiff separation board



747 WHEELS

175X30X54CM / 190X30X54CM / 220X30X60CM

DETAILS

REF.	22233-0203
SIZING.	175x30x54CM / 190x30x54CM / 220x30x60CM
WEIGHT.	5.5KG
COLORS.	BLACK

FEATURES

- Premium 600D Polyester fabric
- Upper waterproof pocket
- High quality wheels
- Inside mesh pockets
- 4 reinforced handles
- Inside tightening straps
- 8mm protection foam
- Bottom reinforcement
- 10mm High density protection foam
- Inside stiff separation board



FOIL WHEELS

5'0 / 5'5 / 6'0
160X64X24CM / 170X75X24CM / 180X85X24CM

DETAILS

REF.	22233-0206
SIZING.	5'0 - 160x64x24CM / 5'5 - 170x75x24CM / 6'0 - 180x85x24CM
WEIGHT.	2.7KG
COLORS.	BLACK

FEATURES

- Premium 600D Polyester fabric
- Zip area
- Removable inside layer protect
- Four side handles
- 10mm High density protection foam
- Inside stiff separation board



BIGGIE

160L - 92X58X34CM

DETAILS

REF.	22233-0205
SIZING.	160L - 92x58x34CM
WEIGHT.	3.15KG
COLORS.	BLACK

FEATURES

- Premium 600D Polyester fabric
- Straps reinforcements + aluminium tension hooks
- 6 reinforced handles
- 1 mesh pocket
- 1 accessories pocket

FEATURES

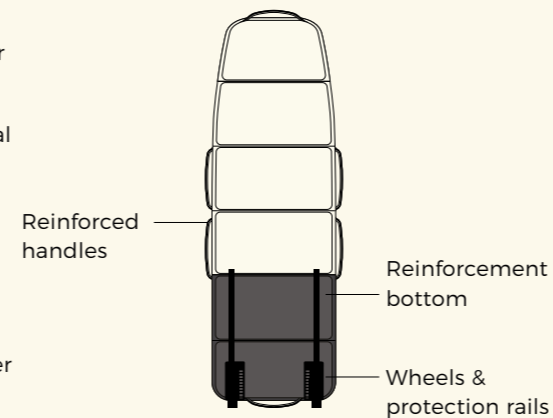
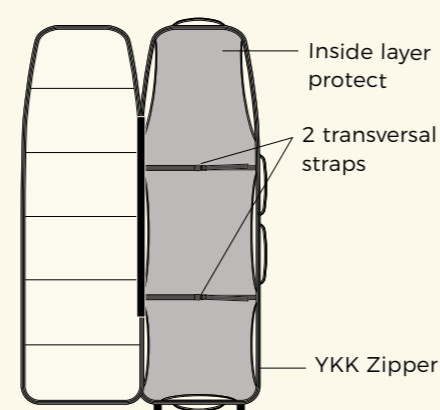

747 WHEELS

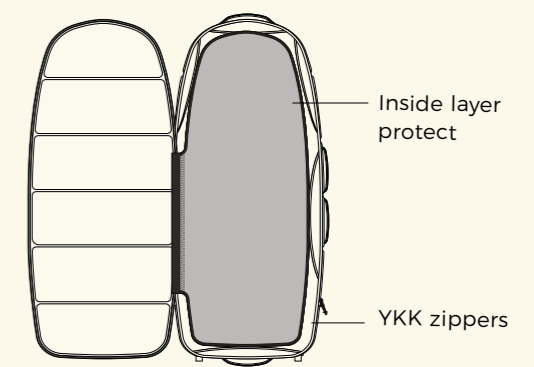
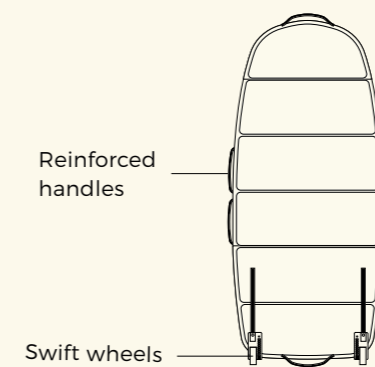

FOIL WHEELS

Daybags.

25

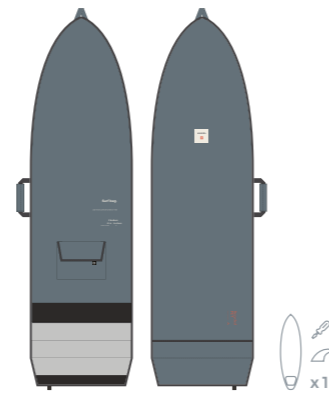

SURF

5'3 / 5'6 / 6'0
163X53CM / 175X54CM / 188X58CM

DETAILS

REF. 22223-0104 / 22223-0105
22223-0106
SIZING. 5'3 -163x53CM / 5'6 -174x54CM
6'0 -188x58CM
WEIGHT. 1.2KG
COLORS. SLATE

FEATURES

- Premium 600D Polyester fabric
- Velcro pocket
- One side handle
- Sleeve roll = Velcro closure, no zipper

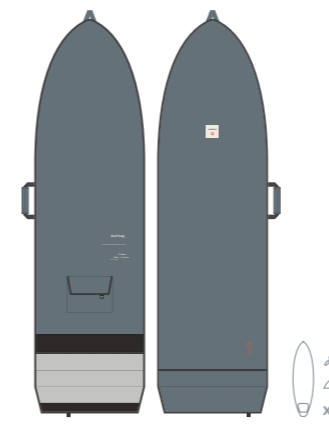

SURF

6'5 / 7'2
170X55CM / 180X60CM

DETAILS

REF. 22223-0107 / 22223-0108
SIZING. 6'5 -200x60cm / 7'2 -220x66CM
WEIGHT. 1.2KG
COLORS. SLATE

FEATURES

- Premium 600D Polyester fabric
- Velcro pocket
- One side handle
- Sleeve roll = Velcro closure, no zipper

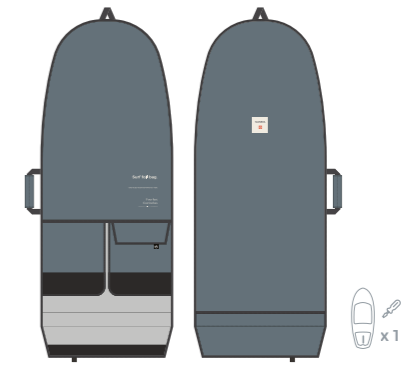

SURF FOIL

4'4 / 4'8
135X60CM / 145X65CM

DETAILS

REF. 22223-0109 / 22223-0110
SIZING. 4'4 -135x60cm / 4'8 -145x65CM
WEIGHT. 1KG
COLORS. SLATE

FEATURES

- Premium 600D Polyester fabric
- Velcro pocket
- One side handle
- Sleeve roll = Velcro closure, no zipper

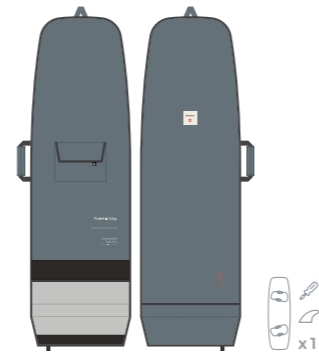

TWIN-TIP

145X50CM - 1KG

DETAILS

REF. 22223-0101
SIZING. 5'0 -145x50CM
WEIGHT. 1KG
COLORS. SLATE

FEATURES

- Premium 600D Polyester fabric
- Velcro pocket
- One side handle
- Sleeve roll = Velcro closure, no zipper

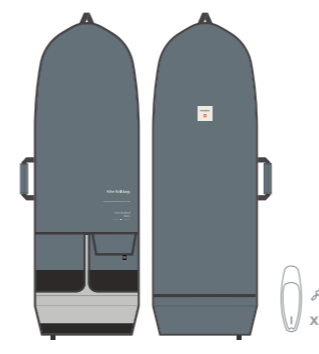

KITE FOIL

130X50CM/145X60CM

DETAILS

REF. 22223-0102 / 22223-0103
SIZING. 4'4 -130x50CM / 5'0 -145x60CM
WEIGHT. 1KG
COLORS. SLATE

FEATURES

- Premium 600D Polyester fabric
- Velcro pocket
- One side handle
- Sleeve roll = Velcro closure, no zipper

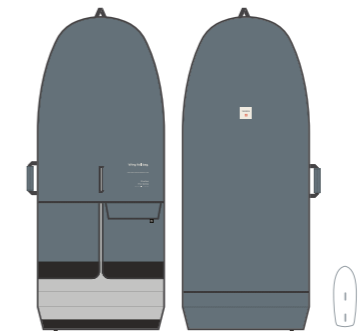

WING

5'0 / 5'5 / 6'0
156X70CM / 170X75CM
185X85CM

DETAILS

REF. 22223-0111 / 22223-0112
22223-0113
SIZING. 5'0 -156x70CM / 5'5 -170x75CM
6'0 -185x85CM
WEIGHT. 1KG
COLORS. SLATE

FEATURES

- Premium 600D Polyester fabric
- Velcro pocket
- One side handle
- Sleeve roll = Velcro closure, no zipper

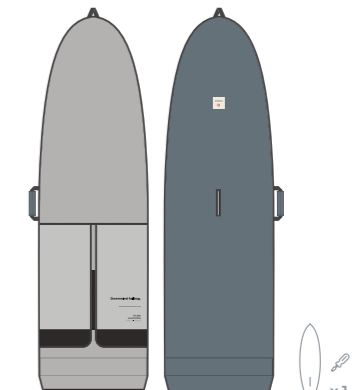

NEW

SUP DOWNWIND

6'7 / 7'0 / 7'5 / 8'0
207X65CM / 217X68CM
230X70CM / 240X72CM

DETAILS

REF. 22243-0114 / 22243-0115
22243-0116/22243-0117
SIZING. 6'5 -207x65CM / 7'0 -217x68CM
7'5 -230x70CM / 8'0 -240x72CM
WEIGHT. 1KG
COLORS. SLATE

FEATURES

- Premium 600D Polyester fabric
- Velcro pocket
- One side handle
- Sleeve roll = Velcro closure, no zipper

Foilbags.

25

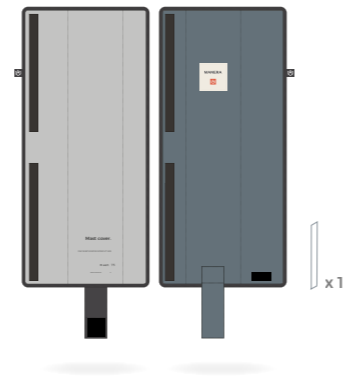

MAST COVER

65 / 75 / 85 / 95 / 105CM

DETAILS

REF. 22223-0301
SIZING. 65 / 75 / 85 / 95 / 105CM
COLORS. SLATE

FEATURES

- Premium 600D Polyester fabric
- High density foam protection
- Velcro closure

B A C K F E A T U R E S

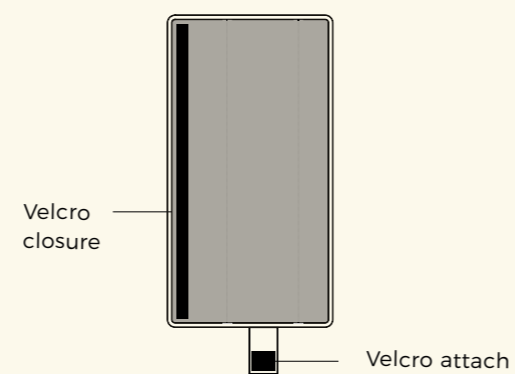

MAST COVER

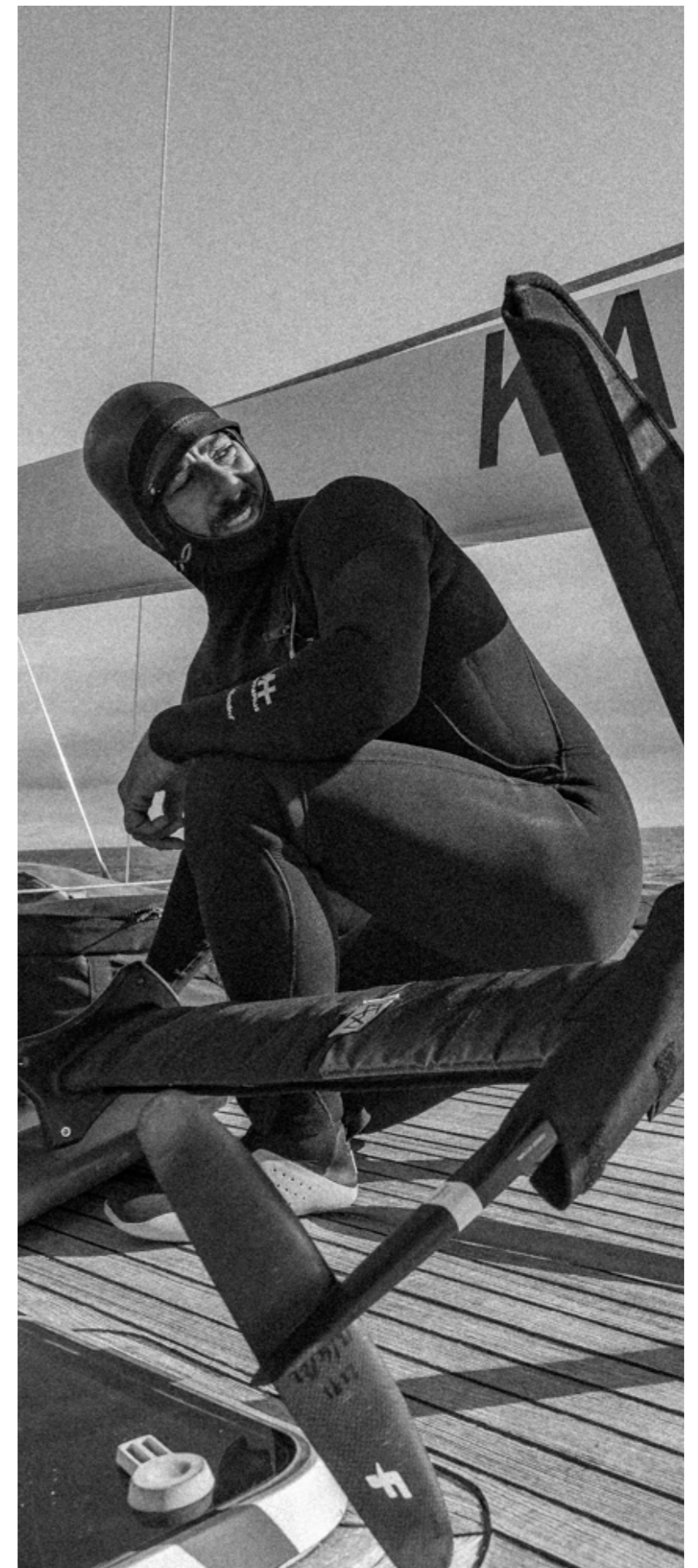

Backpacks.

25



RUGGED DRY DUFFLE

45 L
65 X 30 X 23 CM

DETAILS

REF. **22233-0401**
SIZING. 45L - 65x30x23CM
COLORS. BLACK

FEATURES

- Premium coated Polyester material
- Removable backpack straps
- 1 side expandable pocket
- 1 outside pocket
- 2 inside mesh pockets
- WARNING : 45L Fabric is waterproof but zipper is not.



RUGGED DRY BAG

30 L
73-(53 ROLLED) X 31X19 CM

DETAILS

REF. **22233-0402**
SIZING. 30L - 73-(53 rolled)x31x19CM
COLORS. BLACK

FEATURES

- Premium coated Polyester material
- Mesh shoulder straps
- 1 outside pocket
- 1 inside mesh pocket
- Computer pocket
- WARNING : Bag and pocket zipper are waterproof.

FEATURES

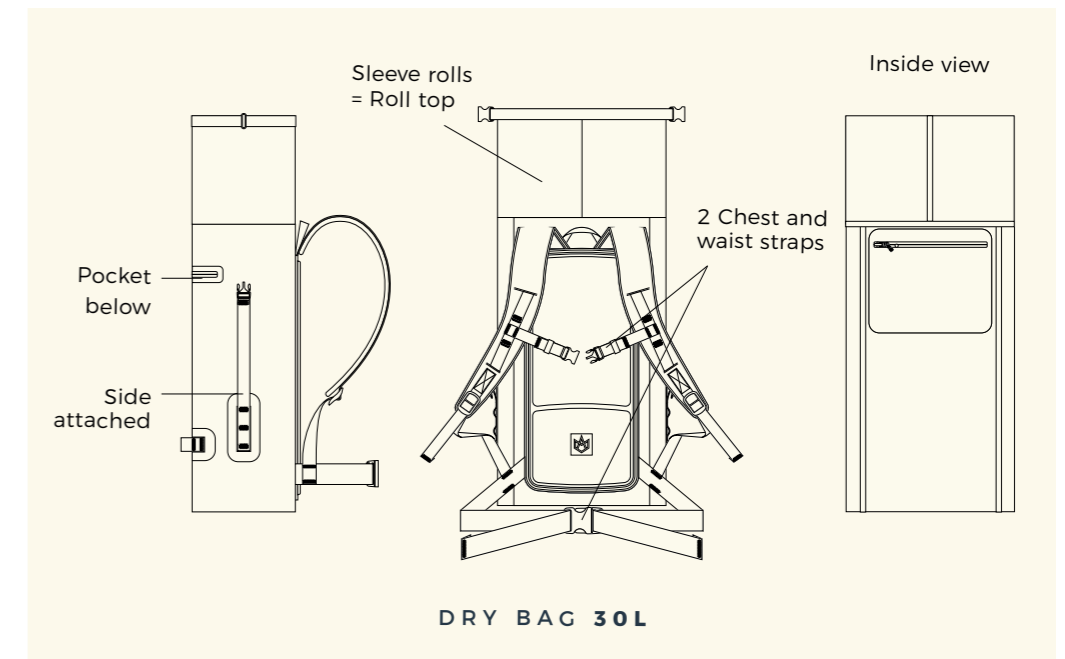
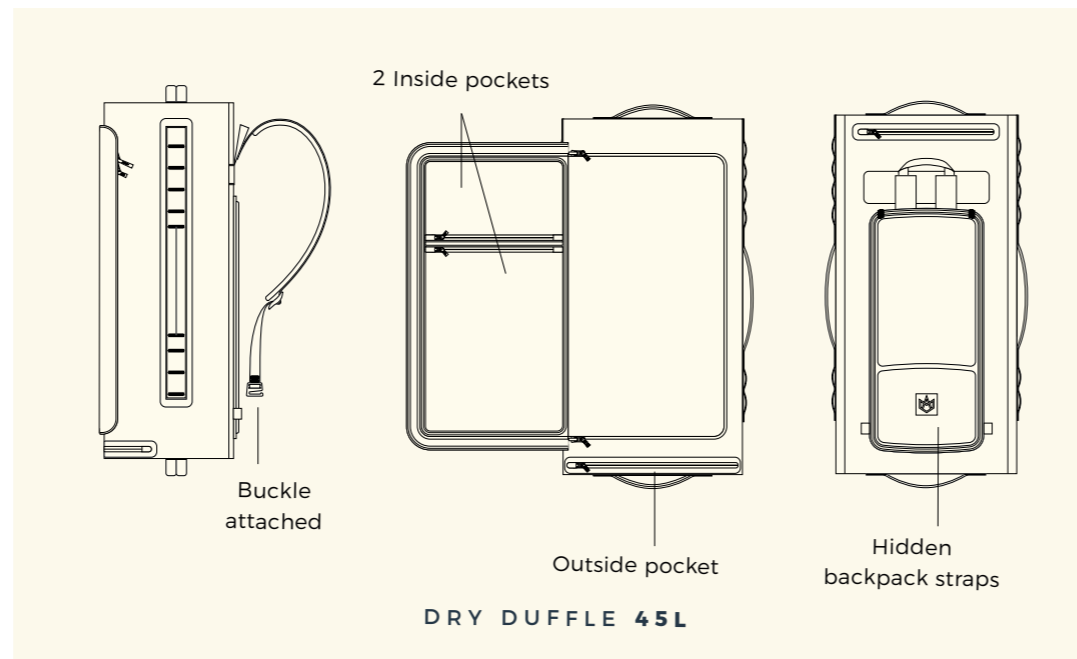

WATERGEAR & PROTECTIONS

OVERVIEW

WATERGEAR

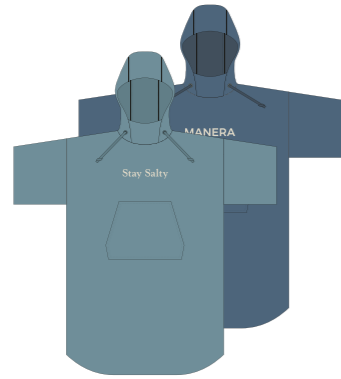

BAMBOO PONCHO
WINTER
Ref. 22236-0300
Sizes. ONE SIZE
Colors. SMOKE BLUE / TEAL

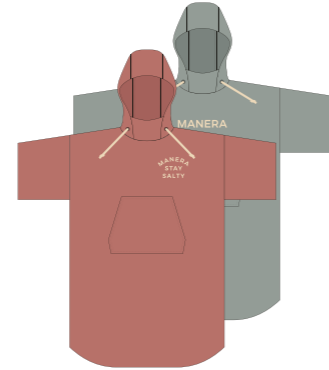

BAMBOO PONCHO
SUMMER
Ref. 22216-0301
Sizes. ONE SIZE
Colors. BRICK / SEAGREEN



ESKIMO PONCHO
Ref. 22246-0302
Sizes. S-L
Colors. NAVY



WATERCAP
Ref. 22246-0501
Sizes. UNIQUE SIZE
Colors. BLACK / GINGER



BOBBY
Ref. 22246-0600
Sizes. S-M-L
Colors. BLACK / GINGER



WING PADDLE ATTACHMENTS
Ref. 22246-1101
Sizes. Unique
Colors. BLACK



WETSHIRTS LS
Ref. 22225-0900
Sizes. XS-S-M-L-XL
Colors. PWETER



WETSHIRT SS
Ref. 22225-1000
Sizes. XS-S-M-L-XL
Colors. STEEL



OFFSHORE VEST
Ref. 22246-1100
Sizes. S-M-L-XL
Colors. GINGER



NEW **BOBBY**
Ref. 22246-0601
Sizes. S-M-L
Colors. BLACK / PALE KHAKI



NEW **DEFLATER BAG**
Ref. 22256-1200
Sizes. Unique
Colors. GINGER

PROTECTIONS



BOOM VEST
Ref. 22205-0100
Sizes. S-M-L-XL
Colors. SLATE BLACK - ALLOY BLUE / BLACK



X10D VEST
Ref. 22205-0200
Sizes. S-M-L-XL
Colors. INK BLUE / BLACK



VAGABOND VEST
Ref. 22245-0501
Sizes. XS-S-M-L-XL
Colors. BLACK / GINGER



SFOAM HELMET
Ref. 22235-0302
Sizes. S-M-L
Colors. BLACK

LEASHES



LEASH BELT
Ref. 22246-0201
Sizes. S-M-L
Colors. BLACK



LEASH FOIL
Ref. 22236-0202
Sizes. 4'5 / 5'5
110 / 130
Colors. BLACK

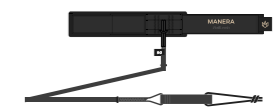

NEW **LEASH FOIL LITE**
Ref. 22246-0203
Sizes. 90 / 110 / 130 / 150CM
Colors. BLACK

Watergear. 25



The Essentials



BOBBY

DETAILS

REF. 22246-0600

SIZING. S-M-L

COLORS. BLACK / GINGER

- FEATURES**
- Polyester 93%
 - Elastane 7%
 - Casual



WATERCAP

DETAILS

REF. 22246-0501

SIZING. UNIQUE SIZE

COLORS. BLACK / GINGER

- FEATURES**
- Fitted fo riding
 - Waterproof and ultra light fabric
 - Breathable side mesh



OFFSHORE VEST

DETAILS

REF. 22246-1100

SIZING. S-M-L-XL

COLORS. GINGER

- FEATURES**
- Backpack + Hydration bag
 - Deflator straps
 - Front pockets for phone and radio
 - Integrated flashlight



WING PADDLE ATTACHMENTS

DETAILS

REF. 22246-1101

SIZING. UNIQUE

COLORS. BLACK

- FEATURES**
- Buckle protection



NEW **DEFLATER BAG**
DOWNWIND

DETAILS

REF.	22256-1200
SIZING.	Unique
COLORS.	GINGER

The DEFLATER BAG, unlike the more versatile OFFSHORE VEST, is dedicated solely to downwind deflators.

Made of ripstop and Dacron from kites and wings, it's ultra-light, waterproof and resistant, so you don't feel it on your back.

Compression straps and Velcro fasteners secure it to your back when empty and when riding upwind. Then, its large pocket and roll-top closure allow you to fit a wing of 5m² or more inside.

An opening on the underside allows water to be drained off when the wing is stowed away, and the ultra-simple closing system ensures that no water enters once the wing is inside, even during heavy falls.

It also features a compartment for a hydration pack (non included).

The DEFLATER BAG is the ultimate gear for your downwind deflators!

We advise you to use the WING PADDLE ATTACHMENTS we've developed, so that you can secure your paddle along the central strut of your wing.

A word about "deflating":

SUP foil downwind is becoming increasingly popular, but the logistics of a downwinder are complicated. Riding upwind with a wing, deflating, and then paddling out is much more practical: no car, possibility of choosing the length of your DW, etc.

MANERA has therefore decided to create lightweight, practical equipment adapted to this new sport, such as the OFFSHORE VEST and the DEFLATER BAG.

Disclaimer: Downwinding require physical preparation, proper security devices, and assistance at sea. Please do not attempt any downwinders alone or without proper training.



NEW

BOBBY
5 PANELS

DETAILS

REF. 22246-0601
SIZING. S-M-L
COLORS. BLACK / PALE KHAKI

FEATURES

- Polyester 93%
- Elastane 7%
- Casual



WETSHIRT SS
SUNSHELL

DETAILS

REF. 22225-1000
SIZING. XS-S-M-L-XL
COLORS. PWETER
COMPOSITION. 86% POLYESTER
14% SPANDEX

FEATURES

- Fast drying
- Wind proof
- Hyper stretch



WETSHIRTS LS & SS
SUNSHELL

DETAILS

REF. 22225-0900
SIZING. XS-S-M-L-XL
COLORS. STEEL
COMPOSITION. 86% POLYESTER
14% SPANDEX

FEATURES

- Fast drying
- Hyper stretch
- Windproof
- Warm



BAMBOO PONCHO
WINTER

DETAILS

REF. 22236-0300
SIZING. ONE SIZE
WEIGHT. 550G
COLORS. SMOKE BLUE / TEAL

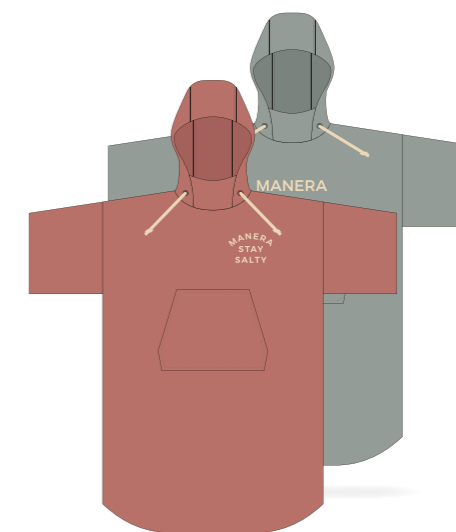

BAMBOO PONCHO
SUMMER

DETAILS

REF. 22216-0301
SIZING. ONE SIZE
WEIGHT. 350G
COLORS. BRICK / SEAGREEN



ESKIMO PONCHO

WINTER

DETAILS

REF.	22246-0302
SIZING.	S-L
WEIGHT.	550G
COLORS.	NAVY

We have fused our BLIZZARD with our high-quality ponchos in order to offer the ultimate winter accessory. The outside features a waterproof, windproof and light shell that protects you from the elements, while the inside towel provides extra warmth and keeps you dry.

Stay warm and dry in the worst winter conditions.

STAY DRY

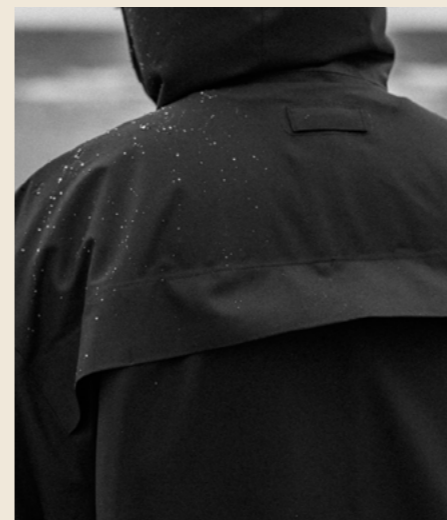

T E C H N O S



Water / wind repellent

The outside waterproof, windproof and light shell protects you from the elements.



Inner soft towel

The inside towel provides extra warmth and keeps you dry.



Warm hand pockets

The ESKIMO features two hand pockets on the chest, which include a soft towel inside to keep your hands warm and dry.



Nylon zipper

The strong, non-corrosive zipper ensures a long-lasting product, even when exposed to saltwater.



Protections.

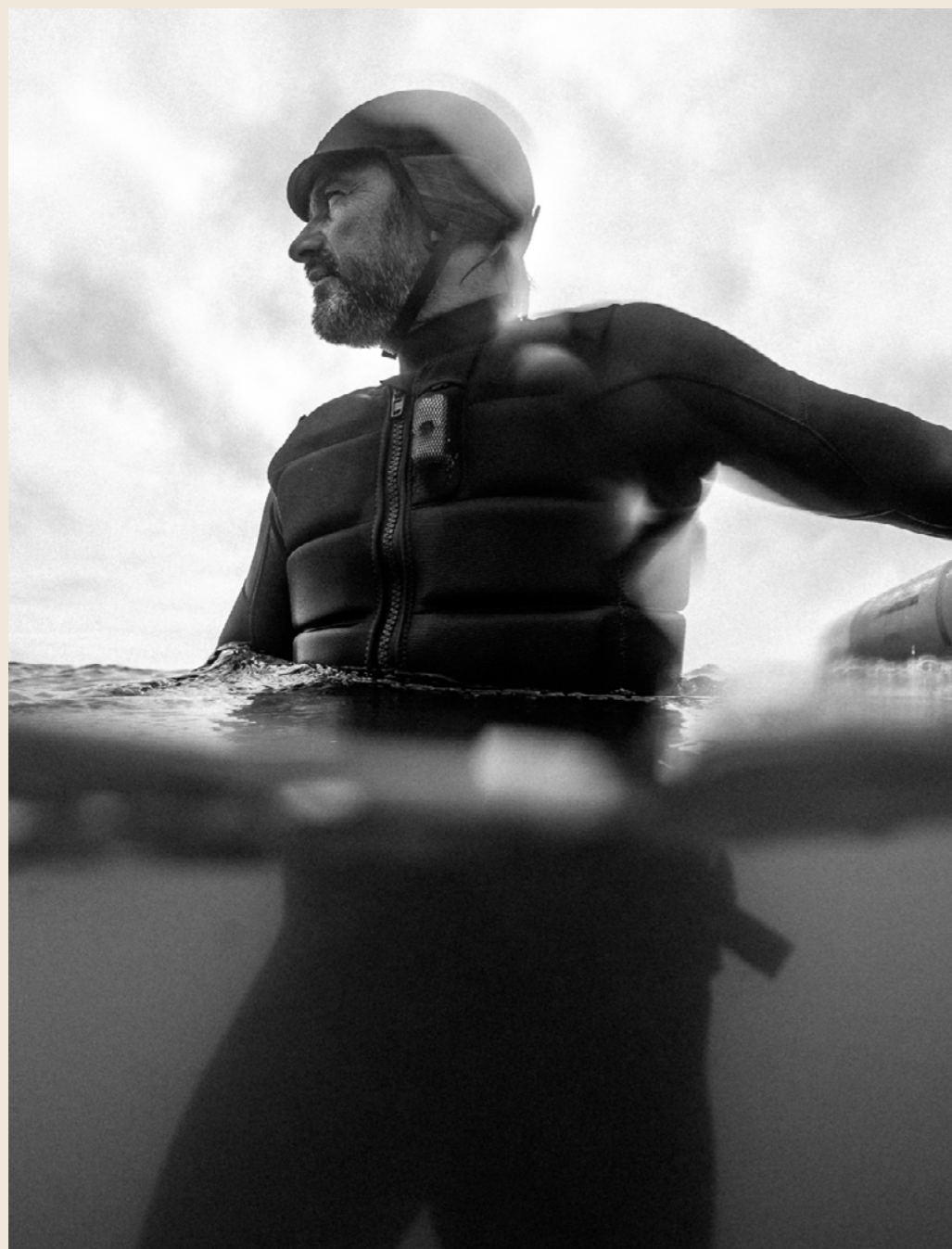

The Essentials



BOOM VEST IMPACT VEST

DETAILS

REF.	22205-0100
SIZING.	S-M-L-XL
COLORS.	BLACK

FEATURES

- Shot gum foam
- Hyper stretch - X10D jersey
- Harness zone
- Anti-slip
- Zipper closure



X10D VEST IMPACT VEST

DETAILS

REF.	22205-0200
SIZING.	S-M-L-XL
COLORS.	BLACK

FEATURES

- Shot gum foam
- Hyper stretch - X10D jersey
- Harness zone
- Anti-slip



VAGABOND VEST

IMPACT VEST

DETAILS

REF. **22245-0501**
 SIZING. XS-S-M-L-XL
 COLORS. GINGER / BLACK

FEATURES

New disciplines often imply new risks. Nowadays, wing foilers are going further offshore to tackle the best bumps. The VAGABOND Impact Vest has been developed to offer a minimalistic, highly comfortable vest featuring all the necessary tools to go offshore.

Be prepared and "Ready to Escape."

READY TO ESCAPE

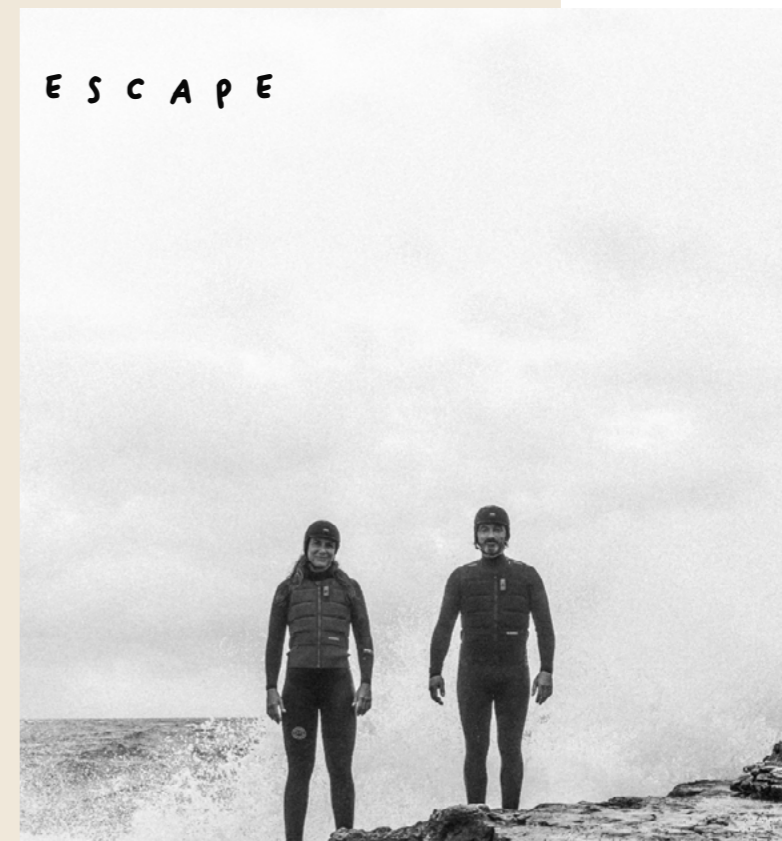

T E C H N O S



Compact & lightweight

Made to provide the best balance between protection and freedom of movement, its thin 15mm foam layer will go unnoticed while riding.

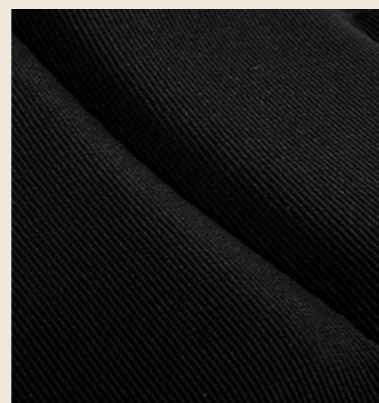

Ready to escape

It features individual PLASTIMMO flashlight, whistle, reflective prints, and leash attachments for your accessories



Big pockets to travel light

Bring your stuff with you, whether it's a tool, some snacks, or your phone; the two front pockets will be useful

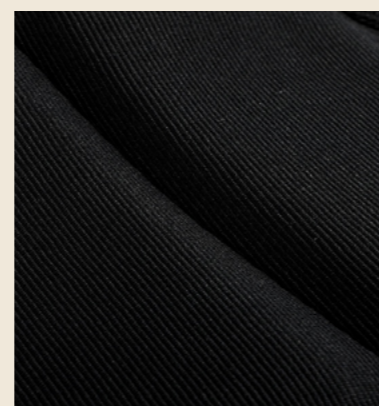

Cut-resistant jersey

We have chosen a specific cut-resistant jersey to avoid any bad injuries due to a kite line, a foil, or anything sharp that you could encounter.





SFOAM HELMET

HELMET

DETAILS

REF. **22235-0302**
 SIZING. S-M-L
 COLORS. BLACK

FEATURES

MANERA is investing a lot to build a protective equipment range. With the rise of winging and foils in general, we believe customers will start using protections as much as when skiing or mountainbiking.

We want MANERA to become the reference.

CE certified

STAY PROTECT



T E C H N O S

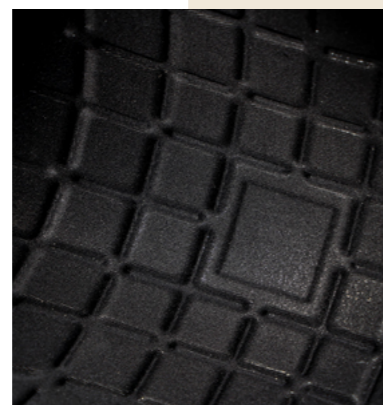

"Smart" Foam

S-FOAM (Smart Foam) is made of a non-Newtonian fluid that is soft and flexible at normal state, but instantly becomes stiff when subject to an impact.

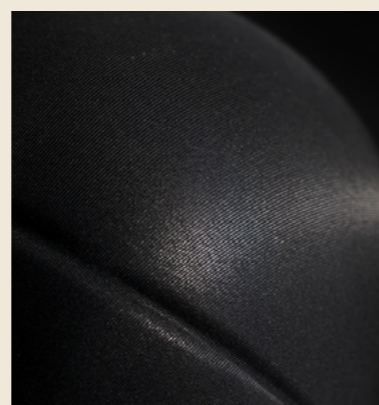

Perfect fit

The helmet is molded into one piece, instead of just trying to assemble a flat pattern into 3D



FACE VIEW

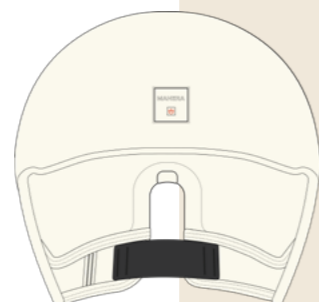

CE certified

BACK VIEW

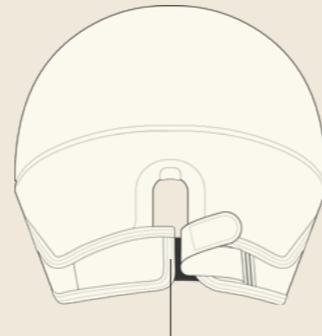

Fix Hypalon

Leashes.



The Essentials

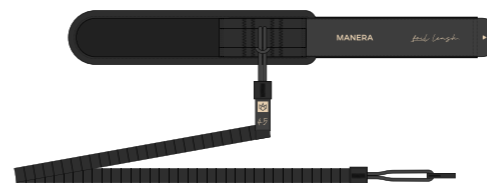

FOIL LEASH

DETAILS

REF.	22236-0202
SIZING.	4'5 / 5'5 110 / 130
COLORS.	BLACK

FEATURES

- Short lenght leash
- Flatter rope = No problem to step on
- Can be easily switched from surfoil to wingfoil board.

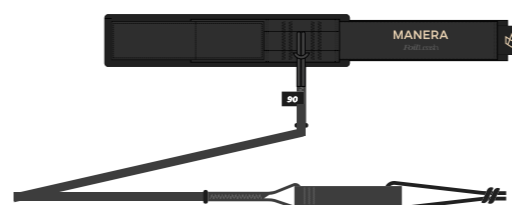

NEW

FOIL LEASH LITE

DETAILS

REF.	22246-0203
SIZING.	90 / 110 / 130 / 150CM
COLORS.	BLACK

FEATURES

- Short lenght leash
- Flatter rope = No problem to step on
- Can be easily switched from surfoil to wingfoil board.

BOARDSHORTS

OVERVIEW

GAMBAS BOARDSHORT



BLUEBERRY



MONUMENT

GAMBAS

Ref. 22234-0301

Sizes. 28-30-31-32-33-34-36

Colors. BLUEBERRY / MONUMENT



BLACK

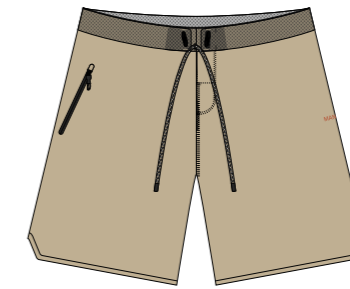

BEIGE

SQUAREFLEX

Ref. 22244-0100

Sizes. 28-30-31-32-33-34-36

Colors. BLACK / BEIGE

HAAPITI BOARDSHORT



GREEN



BLACK

HAAPITI MEN

Ref. 22244-0200

Sizes. 28-30-31-32-33-34-36

Colors. GREEN / BLACK



BLACK

HAPITI WOMEN

Ref. 22234-0100

Sizes. XS-S-M-L-XL

Colors. BLACK

SQUAREFLEX BOARDSHORT

GREEN

BLACK

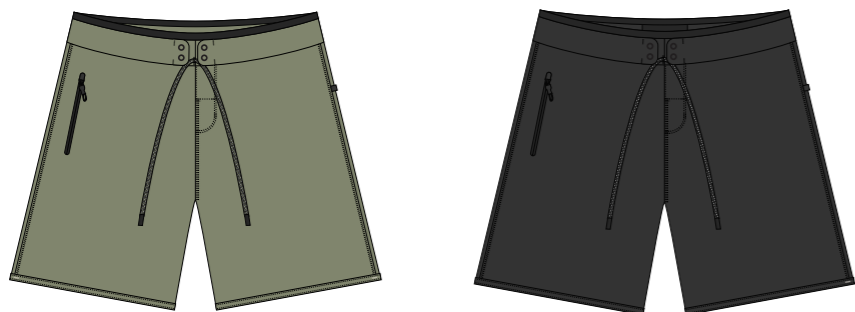

HAAPITI BOARDSHORT

MEN

DETAILS

REF. 22244-0200
SIZING. 28-30-31-32-33-34-36
COLORS. GREEN / BLACK
 - LENGHT 19" -

BLACK



SQUAREFLEX BOARDSHORT

MEN

DETAILS

REF. 22244-0100
SIZING. 28-30-31-32-33-34-36
COLORS. BLACK / BEIGE
 - LENGHT 19" -

BLACK



HAAPITI BOARDSHORT

WOMEN

DETAILS

REF. 22234-2000
SIZING. XS-S-M-L-XL
COLORS. BLACK

BEIGE

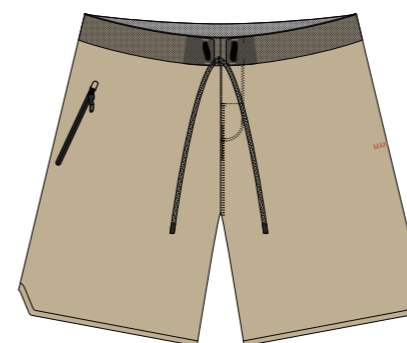

FEATURES

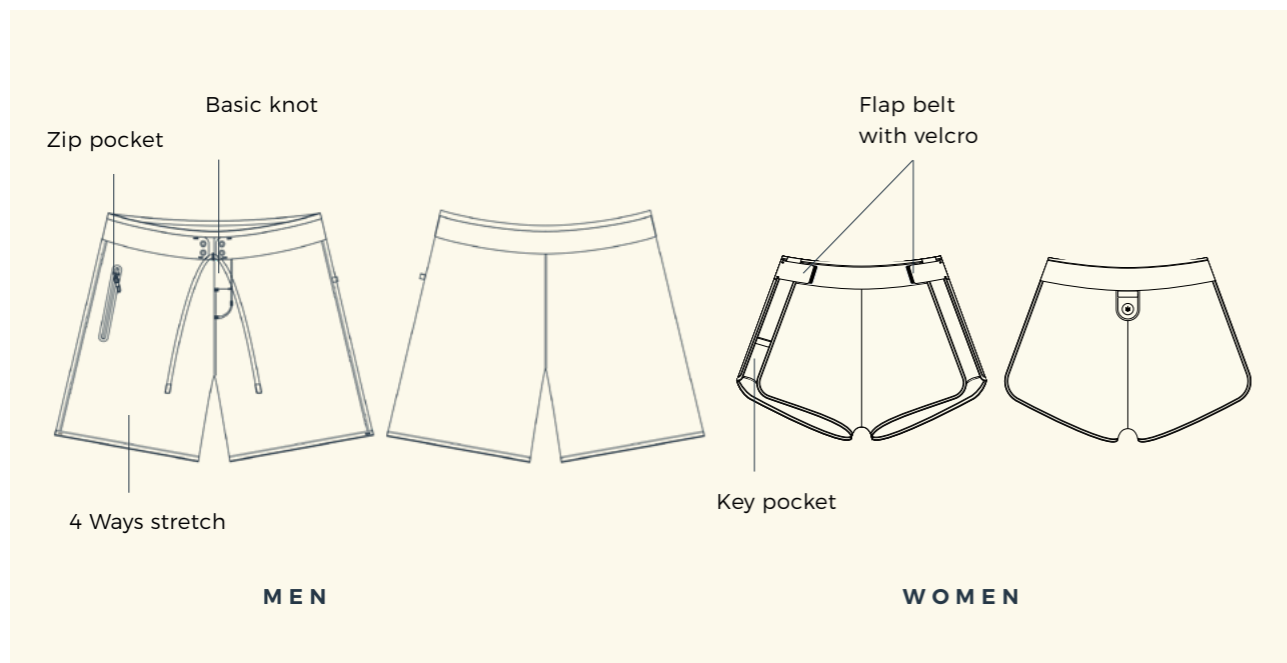

FEATURES

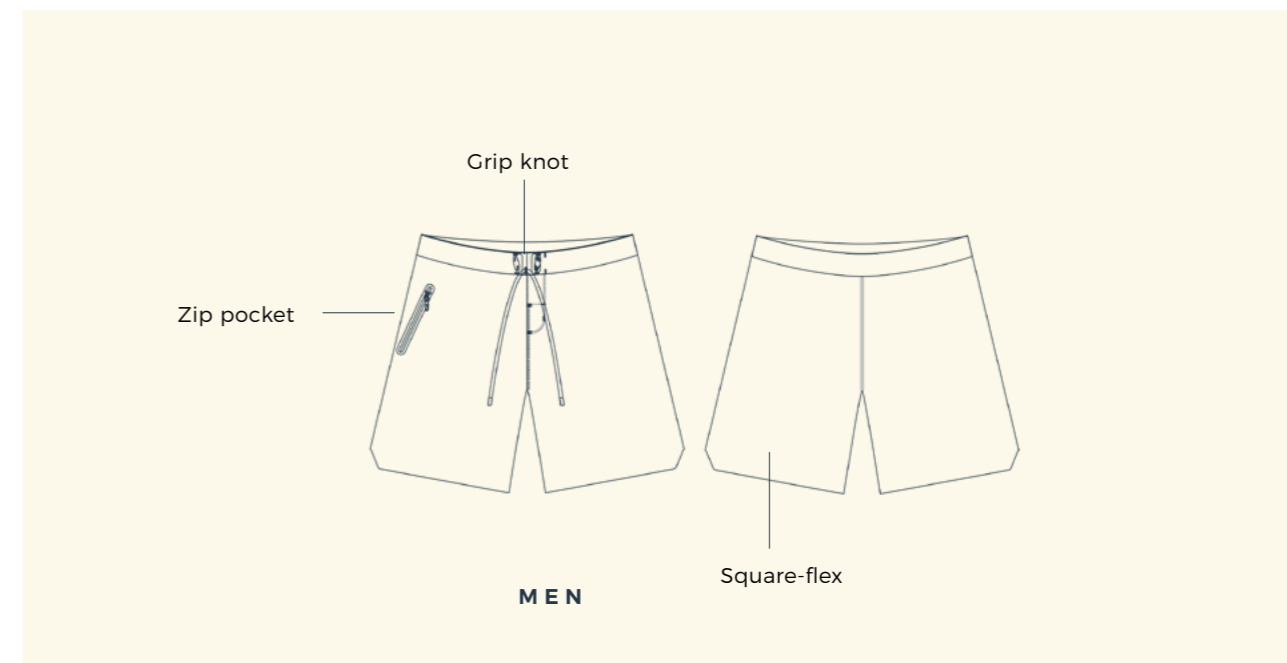

APPAREL

OVERVIEW



TOFU



WINE



BLACK

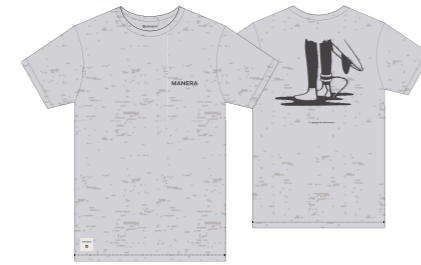

GREY

MEN T-SHIRT

Ref. **22247-0100**

Colors. BLACK / GREY / TOFU / WINE
Sizes XS-S-M-L-XL-XXL

Composition.
Recycled polyester 40%
Organic cotton 60%
160gr



BLACK



TOFU

WOMEN T-SHIRT

Ref. **22247-1000**

Colors. BLACK / TOFU
Sizes XS-S-M-L-XL

Composition.
Recycled polyester 40%
Organic cotton 60%
160gr



NEW MAGMA SOCKS

Ref. **22257-0300**

Colors. WHITE / BLACK
Sizes S / 36-41 - L / 41-46

Composition.
80% Coton
17% Polyester
3% Elastane

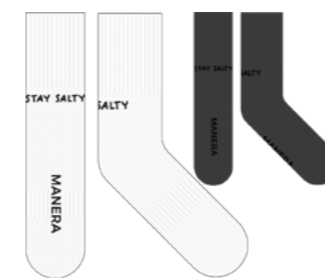

NEW X10D SOCKS

Ref. **22257-0301**

Colors. WHITE / BLACK
Sizes S / 36-41 - L / 41-46

Composition.
80% Coton
17% Polyester
3% Elastane



JUNGLE / Corduroy

ALMOND / Cotton



BLACK / Corduroy

PEWTER / Cotton

CAPS

Ref. **22246-0500**

Colors. JUNGLE / BLACK /
ALMOND / PEWTER

Composition.
Cotton / Wool flanel

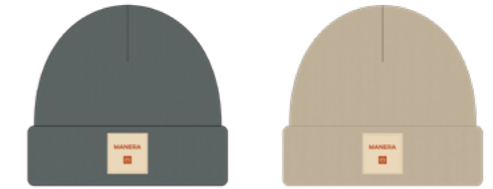

PEWTER

ALMOND



BLACK

MANGO

BEANIES

Ref. **22247-1100**

Colors. PEWTER / ALMOND /
BLACK / MANGO

Composition.
Cotton



BLACK

JUNGLE

UNISEX T-SHIRT RUGGED

Ref. **22247-0101**

Colors. BLACK / JUNGLE
Sizes XS-S-M-L-XL

Composition.
Recycled polyester - 200gr



ALMOND

BLACK

FLEECE

Ref. **22247-0200**

Colors. ALMOND / BLACK
Sizes XS-S-M-L-XL

Composition.
Recycled polyester

SIZECHARTS

WETSUITS MEN

		XS	S	ST	MS	M	MT	LS	L	XL	XXL
WEIGHT	LB	119-136	136-154	136-154	154-171	154-171	154-171	171-189	171-189	189-207	207-224
	KG	54-62	62-70	62-70	70-78	70-78	70-78	78-86	78-86	86-94	94-102
HEIGHT	FT	5'1-5'7	5'3-5'9	5'7-6'2	5'3-5'7	5'5-6'0	5'9-6'3	5'4-5'9	5'7-6'2	5'8-6'4	5'9-6'5
	CM	157-176	162-181	176-191	162-175	170-185	180-195	166-180	175-190	177-196	181-201

WETSUITS WOMEN

		XXS/2	XS/4	S/6	M/8	L/10	XL/12
WEIGHT	LB	92-105	105-119	119-134	134-152	152-167	167-180
	KG	42-48	47-54	54-61	61-69	69-76	76-82
HEIGHT	FT	4'6-5'7	4'8-5'9	4'9-6'0	5'0-6'1	5'2-6'2	5'3-6'3
	CM	143-176	147-180	151-183	155-186	159-190	162-193

HARNESSES

HALO, ECLIPSE & EXO 2.0
2023 and after

	XS	S	S+	M	M+	L	XL
WAISTGIRTH (CM)	68-76	74-82	77-85	82-90	85-93	88-96	94-104
WAISTWIDTH (CM)	24-27	24-27	28-30	28-30	31-34	31-34	31-34
SPREADERBAR (CM)	24	24	28	28	32	32	32

ECLIPSE & EXO 2.0
Before 2023

	XS	S	M	L	XL	XXL
WAISTGIRTH (CM)	70-76	77-84	85-92	93-100	101-109	110-118
SPREADERBAR (CM)	22	24	28	32	34	34

LIFT
Wing harness

	XXS	XS	S	M	L	XL	XXL
WAISTGIRTH (CM)	60-70	67-76	74-83	81-90	88-97	94-104	102-112

LEASH BELT
Wing

	S	M	L
WAISTGIRTH (CM)	68-78	76-94	92-110

WETSUITS GROMS

		8-9	10-11	12-13	14-15
WEIGHT	LB	52-68	68-83	83-99	99-114
	KG	54-62	62-70	70-78	78-86
HEIGHT	FT	4'1-4'8	4'3-5'1	4'6-5'3	4'9-5'6
	CM	126-148	134-156	142-164	150-172

IMPACT VEST

VAGABOND VEST

		XS	S	M	L	XL
HEIGHT	CM	155-175	158-181	162-185	167-188	170-192
	INCH	61-69	62-71	64-73	66-74	67-76
WEIGHT	KG	45-55	55-64	64-74	74-84	84-95
	LB	99-121	121-141	141-163	163-195	185-209

BOOM & X10D VEST

	S	M	L	XL
BODYHEIGHT (CM)	164-176	172-183	176-187	179-190
CHESTGIRTH (CM)	91-97	97-103	103-109	107-114
WAISTGIRTH (CM)	71-79	76-86	83-93	90-98
AVERAGEWEIGHT (KG)	64	72	80	90

SIZECHARTS

HOOD / HELMET

	S	M	L
HEADCIRCUMFERENCE (CM)	-54	55-57	58-60



GLOVES

	S	M	L	XL
1. GLOVELENGTH (CM)	16	17,5	19	20,5
2. PALMWIDTH (CM)	9,5	10	10,5	11



BOOTS

INNER SOLE LENGTH (CM)	22	23	24	24.5	25	25.5	26	27	28	29
UFSIZE	4	5	6.5	7	8	8.5	9.5	10	11	12
EU SIZE	36	37.5	39	40	41	42	43	44	45	46



BLIZZARD JACKET

	S	M	L	XL	XXL
CHEST (CM)	84-88	88-92	92-95	95-99	99-108
WAIST (CM)	74-78	78-82	82-86	86-91	91-98

BOARDSHORTS

	28-XS	30-S	31-M	32-M	33-M	34-L	36-XL
HIPGIRTH (CM)	74	76	79	84	86	89	94

T-SHIRT

	S	M	L	XL	XXL
CHEST (CM)	88-92	92-95	95-99	99-104	104-109
WAIST (CM)	78-82	82-86	86-91	91-96	96-102

SUSTAINABILITY

WE CREATE WITH
CONCIENSCIOUSNESS



UNIQUE SUPPLIER

We have a single, trustworthy supplier with whom we have been closely working since 2012.

SHEICO is a Taiwanese company that produces our goods in Cambodia, and they also produce most of the world's premium wetsuits. Manufacturing around 45 million wetsuits a year, they can have a huge impact on the global wetsuit market's CO² emissions.



RECYCLED NEOPRENE

Before being cut into several slices of a specific thickness, the neoprene is cooked and then shaped into a clean, rectangular slab.

That process involves material waste, which SHEICO recycles and re-uses into finished products, then avoiding industrial wastes that ends up in landfills.

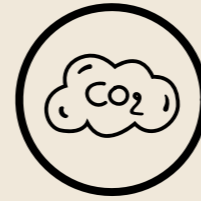

RECYCLED CARBON BLACK

Carbon black is mostly used as a colorant and reinforcing ingredient in the rubber tires industry. It also happens to be a key ingredient in the manufacturing of neoprene.

At SHEICO, carbon black is sourced from pyrolyzed used tires, which reduces energy consumption and saves around 200 g of CO² emissions per wetsuit.

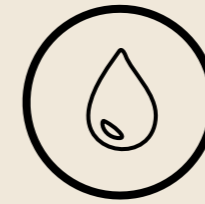

DOPE DYEING CONSUMES 60% LESS WATER

Dyeing the fabric consumes a lot of water, so the threads that make up our fabrics are dyed before being woven. This considerably reduces water usage while reducing energy consumption and water pollution. For other colors, SHEICO has invested in a new generation of dyeing machines which consume 60% less water.

**Only on our black wetsuits*

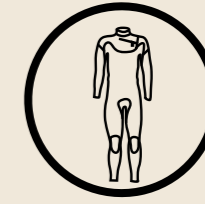

LIMESTONE

All our neoprene goods are derived from limestone rather than petrochemicals.

However, if you think that limestone is much better than oil, think twice.

We still chose to use limestone to reduce our dependency on oil and its derived chemicals. Besides, a limestone spill is much easier to clean up than an oil spill, meaning less danger to the local environment.



YULEX

Yulex Pure® is a natural plant-based rubber that provides a cleaner alternative to traditional petroleum or limestone-based neoprene.

The Yulex® company partnered with FSC certified Hevea tree plantations to harvest crude rubber, then uses its unique process to transform it into a 99% pure solid natural rubber.

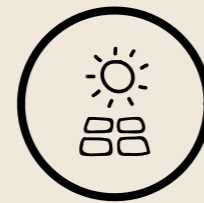

FACTORY POWERED WITH SOLAR ENERGY

The energy that our suppliers use is a crucial part of a brand's carbon emissions. Having an eco-design is useless if your product is made using non-renewable energy.

Therefore, SHEICO factories are equipped with solar panels to limit the use of fossil fuels, generating around 6,038,486kWh per year.



AQUA WATER-BASED GLUE

The glue that binds the jersey fabrics to the internal neoprene foam is now water-based instead of solvent-based.

This removes volatile organic compounds (VOCs), thus providing a healthier working environment for employees and a cleaner wetsuit against your skin.



RECYCLED JERSEYS

MAGMA & XTEND:

This model features a 83% recycled nylon outside jersey and a 100% recycled nylon inside jersey. It helps reduce waste as well as limit the production of new raw material.

ALT:

This model features a 83% recycled nylon outside jersey, a 100% recycled nylon inside jersey, and a 45% recycled fleece. It helps reduce waste as well as limit the production of new raw material.



RECYCLED/COMPOSTABLE PACKAGING

We protect our wetsuits from any contact with humidity or the sun so that they preserve their qualities when they arrive in the shop. We use:

- . A recyclable "pizza box" made of 70% recycled cardboard.
- . A compostable/recyclable bioplastic bag (PLA).
- . Compostable/recyclable bioplastic (PLA) anti-crease tubes.

More info: minima.com

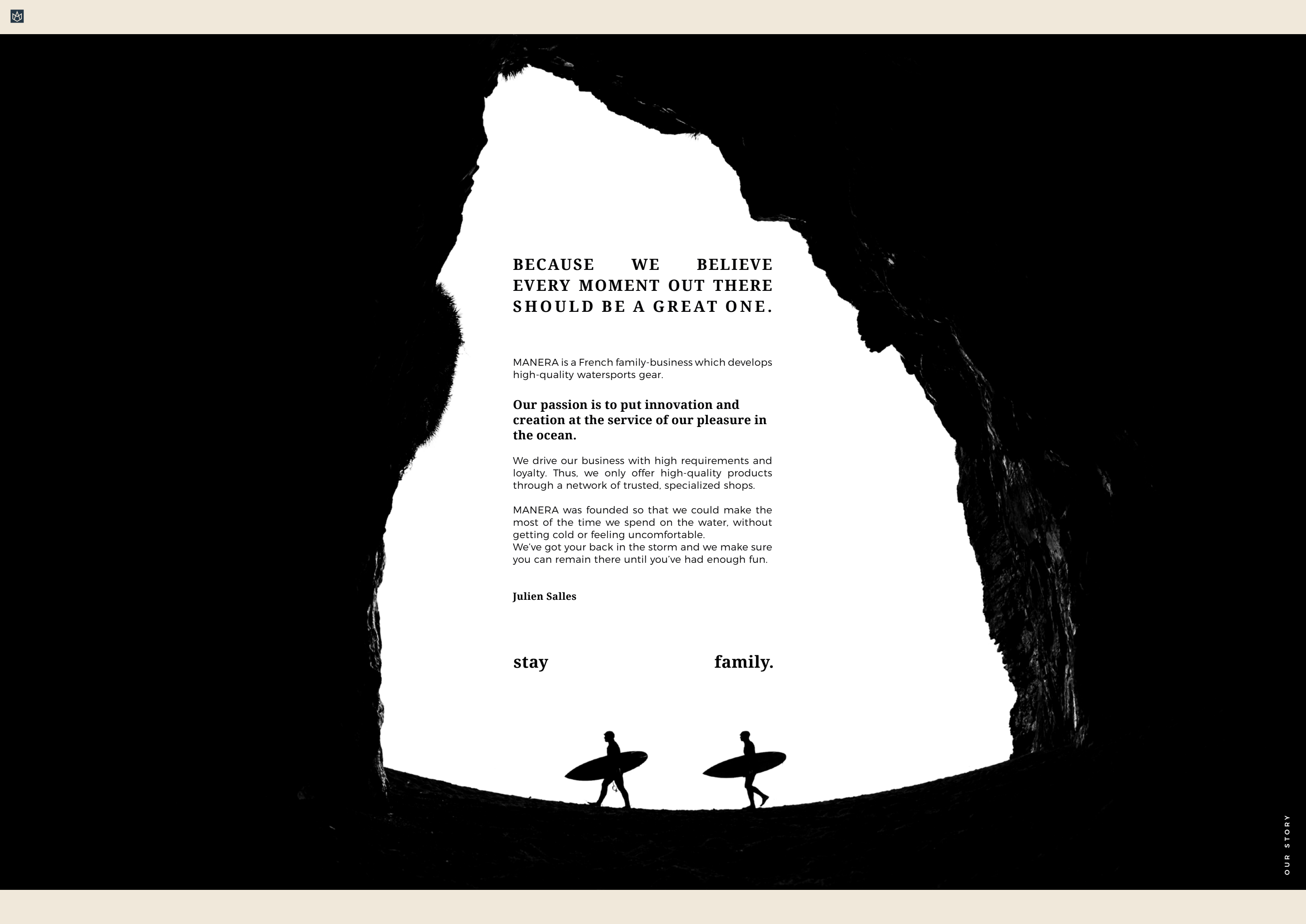

**BECAUSE WE BELIEVE
EVERY MOMENT OUT THERE
SHOULD BE A GREAT ONE.**

MANERA is a French family-business which develops high-quality watersports gear.

Our passion is to put innovation and creation at the service of our pleasure in the ocean.

We drive our business with high requirements and loyalty. Thus, we only offer high-quality products through a network of trusted, specialized shops.

MANERA was founded so that we could make the most of the time we spend on the water, without getting cold or feeling uncomfortable.

We've got your back in the storm and we make sure you can remain there until you've had enough fun.

Julien Salles

stay

family.

F-ONE SAS

ZAC de la Méditerranée
175, Route de la Foire
34470 PÉROLS - FRANCE

Tél. +33 (0) 4 67 99 51 16
Fax. +33 (0) 4 67 99 61 93

WWW.MANERA.COM

